



6th International Conference on Energy and Environment Research, ICEER 2019, 22–25 July,  
University of Aveiro, Portugal

# Analysis and simulation of smart energy clusters and energy value chain for fish processing industries

Ateyah Alzahrani<sup>a,b,\*</sup>, Ioan Petri<sup>a</sup>, Yacine Rezgui<sup>a</sup>

<sup>a</sup> School of Engineering, Cardiff University, Cardiff, United Kingdom

<sup>b</sup> School of Engineering, AlQunfudah Umm Alqura University, Makkah, Kingdom of Saudi Arabia

Received 27 July 2019; accepted 12 September 2019

Available online 24 September 2019

## Abstract

The Irish Seafood agency reports that 15% of global energy is consumed by operations related to refrigeration and air conditioning in the fish industry which stresses the importance of integration with clean renewables and adoption of smart energy management solutions. While fish processing industries have high energy costs with continuous refrigeration, air conditioning and ice making processes, there is a real need to analyse and model energy use in fish ports to understand environmental impacts in terms of CO<sub>2</sub> emissions while exploring the potential for integrating renewable energy sources.

In this paper, we conduct energy modelling and optimization for the Milford Haven fish processing port in South Wales. We explain how a simulation capability can be developed at the fish industry port level and propose a simulation-based optimization strategy to determine optimized schedules for appliances. The results show that energy consumption can be reduced with the use of optimized appliance schedules developed in relation to the total energy demand as well as a wide range of optimization constraints.

© 2019 Published by Elsevier Ltd. This is an open access article under the CC BY-NC-ND license

(<http://creativecommons.org/licenses/by-nc-nd/4.0/>).

Peer-review under responsibility of the scientific committee of the 6th International Conference on Energy and Environment Research, ICEER, 2019.

*Keywords:* Energy analysis; Energy modelling; Simulation; Optimization; Renewable energy; Scheduling appliances

## 1. Introduction

In recent years, the climate has been changed dramatically due to global warming as confirmed by the intergovernmental climate change panel reporting, that since 1950 the atmosphere and ocean currents have increased gradually [1]. The climate change refers to weather conditions of a region or city, but more importantly, it identifies a set of implicit factors that impact the climate change that is now addressed by international environment efforts towards sustainability and decarbonization of fossil fuel [2]. European Union leads one of the first environmental coalitions in the world which targets to reduce CO<sub>2</sub> emissions and increase the use of renewable energy resources

\* Corresponding author at: School of Engineering, Cardiff University, Cardiff, United Kingdom.

E-mail address: [Alzahranaa2@cardiff.ac.uk](mailto:Alzahranaa2@cardiff.ac.uk) (A. Alzahrani).

<https://doi.org/10.1016/j.egy.2019.09.022>

2352-4847/© 2019 Published by Elsevier Ltd. This is an open access article under the CC BY-NC-ND license (<http://creativecommons.org/licenses/by-nc-nd/4.0/>).

Peer-review under responsibility of the scientific committee of the 6th International Conference on Energy and Environment Research, ICEER, 2019.

in different industrial sectors with specific emphasis on reducing carbon emissions, ensuring the security of energy supply and improve EU competitiveness [3,4]. The EU member states have adopted a specific directive to promote electricity from renewable energy resources (2001/77/EC) followed by the renewable energy directive 28/2009/EC for promoting the use of renewable energy resources with 20% of the total power production by 2020 [5,6]. Tackling climate change using smart, efficient and sustainable energy technology represents a productive strategy to reduce CO<sub>2</sub> emission and limit the waste of energy consumption [5,6]. One of the best solutions that can optimize energy use in energy consuming industries is the use of numerical simulation modelling with direct impact on energy savings, time optimization and costs. Such simulation analyses can detect and predict failures and also provide real-time energy optimization in various use-case scenarios. We adopt such modelling principles to deliver a simulation analysis framework utilizing energy modelling software tools to increase energy efficiency for a realistic industrial fish port in Milford Haven, South Wales.

Food and agriculture organization studies have also reported that the global human consumption of fish increased dramatically from 1950 to 2012. The proportion of fish processed world-wide has increased from 20 million tons to more than 136 million tons which adds a level of pressure for fish processing industries to use energy from different sources to meet the demand of fish and for fish processing operations [7,8]. There are various parameters that can influence the energy usage for fish industries such as: (i) seasons when the amount of fishing can increase the demand of energy, (ii) weather that can have a significant effect on the total processed fish during a year and (iii) the number of fisheries and boats that can also effect on total energy use. Energy use for fish processing industries can have two main operating modes: (i) direct use such as lighting system, heating and boxes washing machine or (ii) indirect use through converting the power to another form of energy such as cooling cycle, freezing and equipment. However, due to increase in the demand of energy in industries increase of the cost with energy use and the increase of CO<sub>2</sub> emissions, there is a high necessity to move towards more secure, clean and sustainable energy solutions. New smart energy systems and techniques that have recently emerged can have the capability to meet the requirements of the fish processing industries through increased use of renewable energy and smart energy management.

In this paper, we focus on simulating and modelling energy use in fish processing industries by utilizing tools such as Design-Builder [9], EnergyPlus [10] and Building Control Virtual Test Bed (BCVTB) [11] to model a smart energy cluster and to propose optimized schedules for the site operation. We also study the integration of local PV solar energy in a local energy cluster using a multi-building energy coordination model developed in EnergyPlus. The paper demonstrates the benefits of smart cluster energy systems by leveraging on the demand and supply mechanisms with adequate optimization strategies. We also study the ability to optimize energy using appliance scheduling techniques for the Packaway building and assess impact within the overall energy cluster. The results show that smart energy clusters incorporating local solar energy production can meet the total power demand of fish processing industries greatly optimizing appliances operation time as identified in the trial project at Milford Haven port in South Wales. The remainder of this paper is as follows: Section 2 presents the methodology adopted in this study, Section 3 highlights the use-case implemented in our work and Sections 4 and 5 deliver the evaluation of the study and the simulation-based optimization. We conclude in Section 6.

## 2. Methodology

The research presented in this paper is developed in the context of the EU INTERREG piSCES project (Smart energy cluster for the fish processing industry). The piSCES project aims to develop smart energy grids and management solutions for reducing the costs and carbon footprint of energy networks in the fish processing industry. The development of the simulation container for fishery ports is a multi-stage approach and consists in two main stages: (i) Simulation container implementation stage and (ii) Schedule-based optimization stage (see Fig. 1).

### 2.1. Simulation container stage

The first step of the simulation phase is to develop an electrical energy consumption model for fish ports using DesignBuilder, a commercial 3D modeller and energy simulation software platform. The energy model includes geometrical information of the building enriched with occupancy information, material and envelope properties, overall intrinsic attributes (including thermal properties) of the building, schedules for heating and cooling devices. The simulation model is generated based on a use-case scenario that involves minimizing electrical

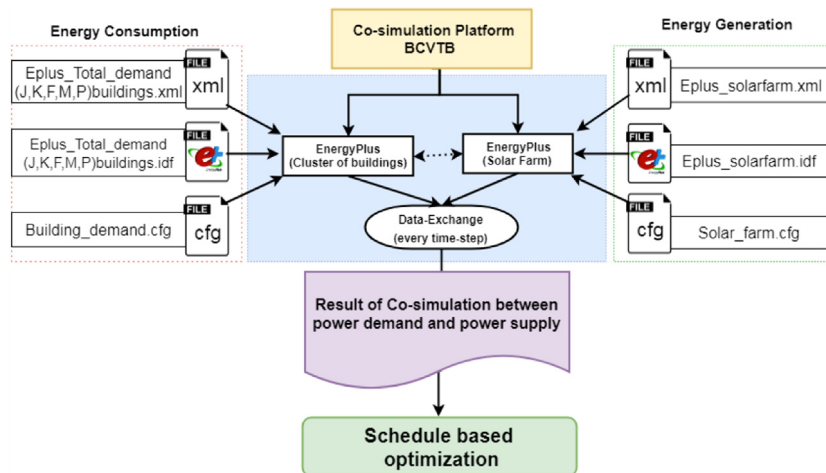

**Fig. 1.** Interface between energy models and power generation sources using BCVTB. Buildings are aggregated into one file and then linked with the solar farm.

energy consumption in the Packaway building while maintaining acceptable CO<sub>2</sub> emissions. The next step is to simulate the scenario based on the different combinations of control variables.

Initially, the thermal model is generated using DesignBuilder, which is exported into EnergyPlus (an open-source and cross-platform energy simulation environment).

## 2.2. Optimization based simulation

The optimization process is based on the simulation of the smart energy cluster system. The optimization is using simulated energy consumption to determine optimized schedules of the appliances. Such optimized schedules represent the time intervals based on which appliances can operate in direct relation with the energy production of the PV system. The optimization stage is directly integrated with the simulation framework developed with DesignBuilder, EnergyPlus and Building control virtual test bed (BCVTB). The simulation-based optimization will inform of the optimal use of appliances in the different time intervals based on specific simulation parameters and values.

## 3. The use-case study modelling

The analyses have been focused on the Milford Haven port with five buildings and a solar farm based on which the entire fish processing workflow is conducted. Packaway building is the main building in the port and contains several appliances consuming energy: a flake ice machine, ice store freezer, box washing machine, lighting systems and smart meter. Also, there are four storage rooms in the Packaway building, and each storage room has a double tube lighting system. The box washing machine has a power capacity of 50k, and it works only when the fishers need to clean boxes during the day. Ice storage is under operation all the time to meet the demand for fish storage with the quantity required. The Packaway building has installed a PV system on the roof of the building with 50 kW panels that feed the building at daytime. They have a total power output of 275 W per panels with two DC–AC inverters. The models have been created based on 2-D drawing, and the internal appliances have been modelled and calibrated based on data collected from the port authority (Fig. 2).

M Shed building is currently occupied by different tenants and has an internal lighting system and several appliances. Units B & C of the building are used as storage facilities while Unit A is used as a boat repair workshop for an incident response provider.

F shed is a new building divided into six units: unit one, unit two at ground floor, unit two at first floor, unit three is also on the ground floor. The ground floor units are used for fish processing; first-floor units are used for storage such as fish containers. The building is still unoccupied except for unit four, which is occupied with some appliances for fish food processing industries.

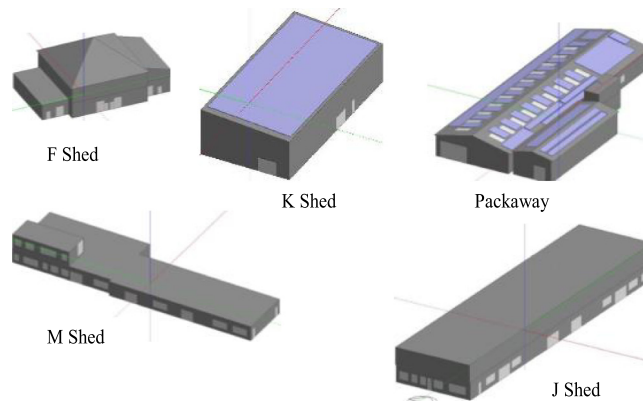

**Fig. 2.** Simulation models of the buildings in the Milford Haven port using DesignBuilder.

J Shed is considered the largest building in the port site and currently is occupied by different stakeholders. It is a complex building and has many electrical systems. The building is split into three occupied units; unit A contains a retail shop with fish processing and office space, fish processing appliances and storage used by individuals for small processing and storage.

K shed is a warehouse. It contains a fridge/freezer used by a stakeholder with a cold room fed mainly from solar PV panels on the roof with a power capacity of 50 kW. There is a chiller storage room used to store fish for the moment, and the chiller is out of service due to technical issues. Also, the main hall has about 62 double tube lighting system. The chiller storage consists of a lighting system and cooling system.

Solar Farm is installed with about 5-MW PV power capacity containing about 20 000 panels. There are four main cabins in the site which are converting DC to AC (32 000 kV) and then linking the solar farm to the national grid.

#### 4. Evaluation and results

The main objective of this study is to model and analyse energy use in the Milford Haven port in a smart energy cluster model and to understand energy demand and supply with their associated constraints. We perform an inventory of the consumption and production units, also considering the carbon emission and potential of making the port a self-operation energy business.

##### 4.1. Integrating buildings with the solar farm

The main objective is to integrate the cluster of buildings with the solar farm through simulation is to investigate the capability of the solar farm to meet the total power demand of the entire site of buildings with their associated operations. Also, we aim to find the optimum management of the energy system in the port by investigating power supply and demand as a first step in the overall optimization process in the port. Co-simulation software has been used, such as building control virtual test (BCVTB) software to connect different types of simulation engines for facilitating the exchange of data between various simulations. The solar farm has been modelled using Simulink and EnergyPlus linked together with BCVTB. Fig. 3 presents the BCVTB models and the main components for the integrations. The model shown in Fig. 3 highlights the conceptual integration between power demand and supply within the energy cluster. To analyse the power supply and demand, we have used two different simulation engines: (i) one evaluating total power demand in the fish industry and (ii) other to simulate solar farm energy generation.

##### 4.2. Simulation results

The power generation source identified by the solar farm has been modelled using EnergyPlus, which enables simulation of the power generation during a year determining insights on how the solar power generation can meet the local power demand

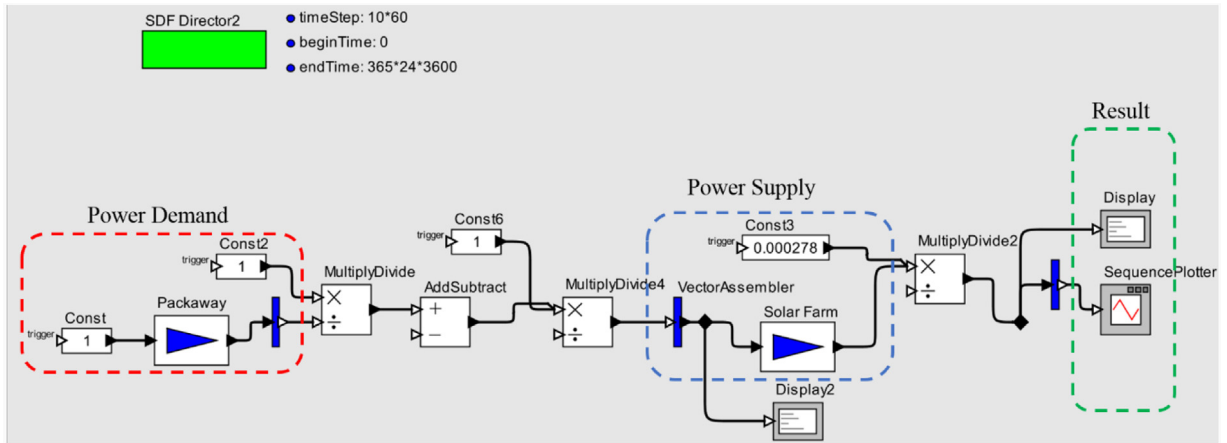

Fig. 3. Integrating power supply and demand in BCVTB.

There are several parameters required for modelling the solar farm such as PV modules properties, number of modules, inverters, the location of the farm, weather data and the total number of panels

Based on the modelling and simulation, Fig. 5 illustrates simulated energy production and consumption in the port over a year, whereas Fig. 4 presents the energy consumption of the individual buildings. It is observed that the energy demand of the port is constant throughout the year while energy production evolves based on the seasons and weather specificities.

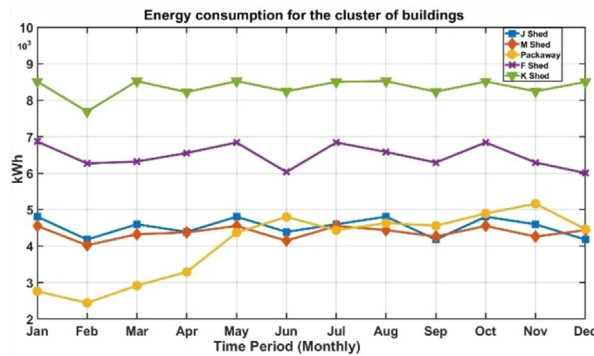

Fig. 4. Total power consumption of the buildings in the Milford Haven port.

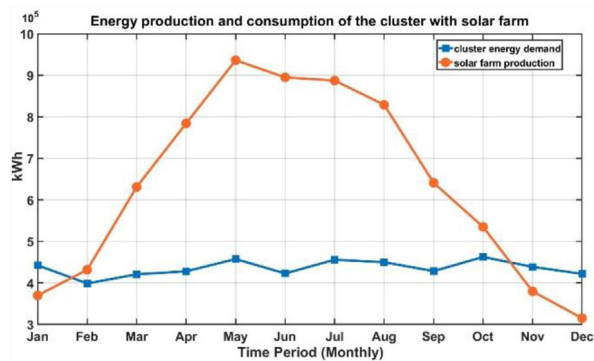

Fig. 5. Result of integrating buildings with the solar farm in BCVTB for the Milford Haven port.

## 5. Optimizing schedules in Packaway

Scheduling appliances are the core of optimization in this study to holistically approach the energy consumption and production in the port. However, to understand the impact of energy consumption, we first apply our analysis on the Packaway building and propose an energy-based scheduling method for smarter energy management. Table 1 shows the trends of energy consumption per appliance at four intervals in the Packaway building, as identified in the simulation.

**Table 1.** Impact of energy consumption per appliance.

Appliance	Total power consumption per day (kWh)			
	24 h	12 h	8 h	4 h
Cold room	720	360	240	120
Flake ice	720	360	240	120
Box washing	120	60	40	20
Lighting	66.15	33.075	22.05	11.025

Table 2 presents the input constraints of the appliances which must be considered for the energy optimization process and integration with renewable energy sources. It considers power capacity, the minimum running time of each appliance, the ability to interrupt appliance and the required start time.

**Table 2.** The appliance usage list in the Packaway building.

Appliance	Total power consumption a day				
	Power rating	Minimum running time (min)	Interruption of appliance	Required usage frequency	Required start time
Cold room	30 kW	30	NP <sup>a</sup>	120	0:00–23:45
Flake ice	30 kW	60	P <sup>a</sup>	120	6:00–16:00
Box washing	50 kW	180	P	20	6:00–16:00
Lighting	25 W/per tube	60	P	11.025	0:00–23:45

<sup>a</sup>NP: Not Possible, P: Possible.

Table 3 presents the optimized time of operation per appliance as resulted from the optimization. It presents the total amount of energy that must be consumed, and the total amount of energy needed either from the local power generation and the national grid.

**Table 3.** Optimized appliances schedules for the Packaway building.

Appliance	Total power consumption	Operational interval
Cold room	240 kWh	8 h/day
Flake ice	120 kWh	4 h/day
Box washing	5 kWh	1 h/day
Lighting	5 kWh	2 h/day

The results presented below are obtained based on the simulation-based optimization process and show the optimized time of operation of appliances by considering different parameters that impact the total power consumption and operation time of each appliance.

Such optimized schedules can orchestrate energy management at the port level and provide more efficient use of resources within the port.

## 6. Conclusion

Due to increased energy consumption in fish processing industries, it has become necessary to find a smarter way to manage energy and to reduce energy consumption. Renewable energy sources and optimized energy strategies at

industries sectors are the key elements that play a vital role in the overall energy management landscape. Applying smart energy management tools can prove to be an efficient and feasible method from an economic perspective, but such solutions can also have an associated modelling complexity. This study is based on a trial project at Milford Haven port and investigates energy optimization by studying the feasibility of integrating renewable energy sources for the existing cluster of buildings. We demonstrate that modelling, analysis and optimization of the energy use in the fish processing industry can have an impact on three aspects: (i) reduce energy consumption, (ii) increase the use of renewable energy sources and (iii) reduce the energy cost. Also, such optimization strategies can have an impact on the environment by reducing the carbon emission and contribute to the global motivation of tackling climate change. This study also contributes to the broader vision of transition towards smart industries with an “exemplar case study” on Milford Haven port started by auditing energy consumption for each individual building in relation to the production of the solar farm. A simulation-based optimization for scheduling appliances has been developed for determining the optimized operation intervals of appliances and optimal use of local renewable energy sources.

### Acknowledgments

This work is part of the EU INTERREG piSCES Project: “Smart Cluster Energy System for the Fish Processing Industry”, grant number: 504460.

### References

- [1] Mitchell JF, et al. Climate response to increasing levels of greenhouse gases and sulphate aerosols. *Nature* 1995;376(6540):501.
- [2] Dore MH. Climate change and changes in global precipitation patterns: what do we know?. *Environ Int* 2005;31(8):1167–81.
- [3] Association EWE. EU energy policy to 2050—achieving 80%–95% emissions reductions. Brussels: EWEA; 2011.
- [4] da Graça Carvalho M. EU energy and climate change strategy. *Energy* 2012;40(1):19–22.
- [5] Directive C. 28/EC of 23 april 2009 on the promotion of the use of energy from renewable sources and amending and subsequently repealing directives 2001/77/EC and 2003/30. Brussels: European Commission; 2009.
- [6] Arasto A, et al. Analysis and implications of challenges in achieving the targets of EU RES-E directive. *Biomass Bioenergy* 2012;38:109–16.
- [7] Muir J. Fuel and energy use in the fisheries sector. FAO Fisheries and Aquaculture Circular (FAO) eng no. 1080, 2015.
- [8] Alzahrani A, Petri I, Rezgui Y. Modelling and implementing smart micro-grids for fish-processing industry. In: 2019 IEEE international conference on engineering, technology and innovation (ICE/ITMC). IEEE; 2019.
- [9] Tindale A. Designbuilder software. Stroud, Gloucestershire, Design-Builder Software Ltd; 2005.
- [10] Crawley DB, et al. Energy plus: energy simulation program. *ASHRAE J* 2000;42(4):49–56.
- [11] Wetter M, Haves P, Coffey B. Building controls virtual test bed. Lawrence Berkeley National Laboratory; 2008.