

# Online Research @ Cardiff

This is an Open Access document downloaded from ORCA, Cardiff University's institutional repository: <http://orca.cf.ac.uk/19660/>

This is the author's version of a work that was submitted to / accepted for publication.

Citation for final published version:

Disney, Stephen Michael and Warburton, Roger D. H. 2012. On the Lambert W function: Economic Order Quantity applications and pedagogical considerations. *International Journal of Production Economics* 140 (2) , pp. 756-764. 10.1016/j.ijpe.2011.02.027 file

Publishers page: <http://dx.doi.org/10.1016/j.ijpe.2011.02.027>  
<<http://dx.doi.org/10.1016/j.ijpe.2011.02.027>>

Please note:

Changes made as a result of publishing processes such as copy-editing, formatting and page numbers may not be reflected in this version. For the definitive version of this publication, please refer to the published source. You are advised to consult the publisher's version if you wish to cite this paper.

This version is being made available in accordance with publisher policies. See <http://orca.cf.ac.uk/policies.html> for usage policies. Copyright and moral rights for publications made available in ORCA are retained by the copyright holders.



## On the Lambert W function: Economic Order Quantity applications and pedagogical considerations

Stephen M. Disney<sup>1#</sup>, Roger D.H. Warburton<sup>2</sup>

<sup>1</sup> Logistics Systems Dynamics Group, Cardiff Business School, Cardiff University, Aberconway Building, Colum Drive, Cardiff, CF10 3EU, UK.  
Tel: +44 29 2087 6310, Fax: +44 29 2087 4301  
[DisneySM@cardiff.ac.uk](mailto:DisneySM@cardiff.ac.uk) # Corresponding Author.

<sup>2</sup> Department of Administrative Sciences, Metropolitan College, Boston University, 808 Commonwealth Avenue, Boston, MA, 02215, USA.  
Tel: +1 617 358 3583, Fax: +1 617 353 6840  
[rwarb@bu.edu](mailto:rwarb@bu.edu)

### Abstract

We illustrate the use of the Lambert W function by analyzing two Economic Order Quantity (EOQ) scenarios: an EOQ model with perishable inventory; and a Net Present Value analysis of an EOQ problem with trim loss. Both scenarios are motivated by real world situations. Via these two examples, we reflect upon the pedagogical aspects of using the Lambert W function. We present a Lambert W function 'look-up' table for classroom use and a Microsoft Excel 'Add-In' for self-study and practical use. We also illustrate the use of the Laplace transform to conduct NPV analyses of the EOQ model.

*Keywords:* Lambert W function, Economic Order Quantity, Net Present Value, perishable inventory, trim loss.

### 1. Introduction

The Lambert W function,  $W[z]$ , is the function that satisfies  $W[z]e^{W[z]} = z$ , where  $e$  is the natural exponential and  $z$  is a complex number. Named after Johann Heinrich Lambert, it is sometimes called the Omega function or the Product Log function [1] and is known as the 'golden ratio of the exponentials'. In general,  $z \in \mathbb{C}$  and the Lambert W function is multi-valued. However, if we restrict  $z \in \mathbb{R}$  then for  $-e^{-1} \leq z \leq 0$  there are only two possible solutions for  $W[z]$ . The 'principle' branch, which satisfies  $W[z] \geq -1$ , is denoted by  $W_0[z]$  and the 'alternative' branch, which satisfies  $W[z] \leq -1$ , is denoted by  $W_{-1}[z]$ . For  $W[z] > 0$  there is only one real solution,  $W_0[z]$ . Figure 1 illustrates the real solutions to the Lambert W function.

Although the Lambert W Function is not well known, it is available in modern computer software packages such as Maple and Mathematica. In Maple, it is known as the 'LambertW' function, and in Mathematica as the 'ProductLog' function. Corless et al [2] recently popularized the Lambert W function, beginning its resurgence as a useful, if under-appreciated function, and suggested the symbol 'W' after the pioneering work of Wright [3]. [2] show that the applications of the Lambert W function are wide ranging but often go unnoticed. They review many practical applications that include the jet fuel

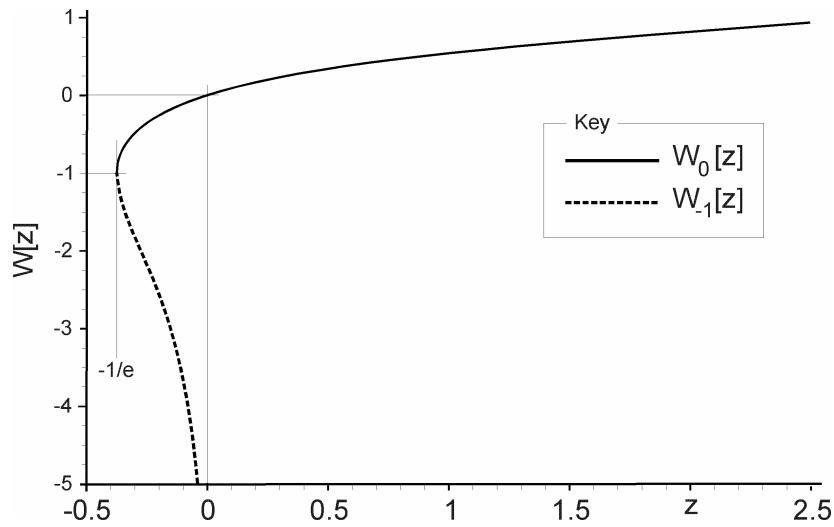

**Figure 1. Real solutions of the Lambert W function**

problem, combustion models, enzyme kinetics, molecular physics, water movement in soil, epidemics, and applications in computer science.

The Lambert W function also plays a role in the stability and evolution of differential delay equations. [4] used the Lambert W function to identify the stability boundary for a supply chain model in continuous time when a pure time delay represents the production and distribution delay. [5] characterised the time evolution of a continuous time production and inventory system, while [6] used the Lambert W function in order to determine expressions for the bullwhip and inventory variance amplification produced by a continuous time Order-Up-To policy. These bullwhip and inventory variance expressions are needed in order to conduct an economic analysis of a system with random demand processes – see [7] for an example of how to achieve this in discrete time.

[8] has recently noted the usefulness of the Lambert W function for certain Economic Order Quantity (EOQ) problems. Specifically, [8] considers EOQ problems when the inventory deteriorates over time, when demand contains a stock dependent term and when the Net Present Value (NPV) of the cash flows is considered.

In this paper we make an additional contribution to literature on the Lambert W function applied to EOQ problems by studying two real cases. First we consider the problem of EOQ with perishable inventory. We note that there is a difference between deteriorating inventory and perishable inventory. In the deteriorating inventory scenario, the inventory physically decays and is destroyed over time, while perishable inventory loses value but it is not destroyed. In a second EOQ scenario we study the net present value (NPV) of the cash flows in an EOQ problem with trim loss. The trim loss aspect is an interesting, if rather trivial, extension of the classic EOQ problem [9]. Our focus is to derive the cash flows via the Laplace transform (rather than directly from the time domain description of the inventory levels and order placements as in [8]), which is novel and more interesting.

We believe the Laplace transform approach has the advantage that descriptions of the cash flows are obtained in a rather concise manner.

Both EOQ problems are motivated by real-world situations, use authentic data and provide practical, compelling observations. The perishable inventory problem follows Blackburn and Scudder's [10] study of a melon supply chain in California, USA, while the NPV of the EOQ with trim loss problem was motivated by the case of VT Foams in the UK [11]. In order to obtain numerical solutions to these EOQ problems it is necessary to have access to the real solutions of the Lambert W function. Therefore, we present a 'look-up' table of the principle and alternative solutions of the Lambert W function for classroom use. We also provide the Visual Basic code needed to write a Microsoft 'Add-In' for calculating the Lambert W function in Excel. We believe that these pedagogical features make this paper an interesting source for teaching the 'Lambert W' function (with only slightly advanced EOQ problems) to postgraduate students in both engineering and business schools.

## 2. EOQ with perishable inventory

Blackburn and Scudder [10] recently investigated the supply chain design for melons. They carefully and clearly describe the melon supply chain, which we briefly summarise. Melons are picked from the vine at time  $t_0$ , at the field temperature (about 30°C), at a rate of  $p$  cartons per hour ("cartons of melons" is the unit of analysis).  $D$  is total annual harvest and  $c$  is the cost of picking one carton, and so  $cD$  is the total annual cost of picking melons. A trailer moves slowly through the field as gangs of pickers toss melons onto the trailer, where they are sorted into cartons depending on size. Each case can hold up to 30 melons; 42 cases of melons make up a crate; and the trailer can hold up to 14 crates of melons. Adding more pickers increases the picking rate.

Before the field trailer is full, the crates of melons are transferred to another vehicle before they are sent to a cooling facility. This transfer vehicle holds a significant amount of melons and may take 3-4 hours to fill by collecting melons from several gangs working the field. The transfer batch is  $Q$  cases of melons and is the decision variable in this case. The cooling facility is typically  $t_r = 15$  mins to 1 hour transport time from the field and is owned and operated by the co-operative of melon farmers. The cost of this transfer is  $\$K$ . The cooling facility uses hydro, forced air or vacuum cooling technologies to cool the melons at time  $t_1$ . The melons remain in the cooling facility until they are sold to the retailer. The transport cost for delivery to retailer  $j$  is  $C_j$ . When the melon reaches the retail store, the cold chain ends at time  $t_2$  and so the time in the cold chain is  $t_2 - t_1 = t_j$ .

Interestingly, as soon as the melons are picked from the vine, they start to lose value as they respire. The temperature of the melon determines the respiration rate and hence the rate of value loss [10]. When held at the field temperature, the value of the melons,  $V$ , falls by a rate of  $\alpha$  per hour. In the cold chain, the value of the melons falls by a rate of

$\beta$  per day. From this case data [10] then go on to justify an appropriate cost function, (see Eq. 3 in [10]), which we repeat below.

$$TC = \frac{KD}{Q} + DV - \frac{D}{Q\alpha} \left( pV e^{-\beta t_j} e^{-\alpha t_r} \right) \left( 1 - e^{-\alpha Q/p} \right) + cD + C_j \quad (1)$$

Ignoring the exogenous variable  $D$  and the constant  $C_j$  the optimisation problem becomes

$$\min TC = \frac{1}{Q} \left( K - \left( p e^{-\beta t_j} e^{-\alpha t_r} V / \alpha \right) \left( 1 - e^{-\alpha Q/p} \right) \right) \text{ s.t. } \{Q, p\} \geq 0. \quad (2)$$

This is equivalent to (Eq. 5 in [10]) when their small error with the second closing bracket of the RHS is corrected. [10] show that the optimal  $Q$  satisfies (Eq. 6 in [10])

$$Q = \left( \frac{p}{\alpha} - \kappa \right) e^{\alpha Q/p} - \frac{p}{\alpha} \quad (3)$$

where the constants in (Eq. 6 in [10]) have been replaced by  $\kappa = e^{\alpha t_r + \beta t_j} K / V$  for ease of exposition. Failing to recognise that this equation has an exact solution via the Lambert W function, [10] provide an approximate solution based on a Taylor Series Expansion with the following lower bound,

$$Q \geq \sqrt{\frac{2p\kappa}{\alpha}} = \sqrt{2} \sqrt{\frac{Kp e^{\alpha t_r + \beta t_j}}{V\alpha}}. \quad (4)$$

Equation (4) implies that  $Q^*$  exists if  $\frac{Kp}{V\alpha} < 0$ , which can only happen if an odd number of  $\{K, p, V, \alpha\}$  are negative. However, given the context of these variables, this cannot happen, and so (4) implies an optimal  $Q$  always exists.

This approximation is not necessary. There is an easily obtainable, exact solution in terms of the Lambert W function. The general approach is to transpose all the  $Q$ 's to the right hand side (RHS) of the equation, with the goal of manipulating it into the form  $y = xe^x$ . The optimal  $Q$  can then be determined by inspection of the Lambert W function:  $x = W[y]$ . For the melon case, we start from (3) and collect all the  $Q$ 's on the RHS by multiplying throughout by  $e^{-\alpha Q/p}$ ,

$$\frac{p}{\alpha} - \kappa = \left( Q + \frac{p}{\alpha} \right) e^{-\alpha Q/p}. \quad (5)$$

Multiplying by  $-\alpha/(pe)$  yields

$$\frac{\kappa\alpha}{pe} - \frac{1}{e} = \left( -\frac{Q\alpha}{p} - 1 \right) e^{\left( -\frac{Q\alpha}{p} - 1 \right)}, \quad (6)$$

which is in the form required by the Lambert W function, and the solution is then given by  $x = W[y]$ . Thus the exact solution is:

$$-\frac{Q\alpha}{p} - 1 = W_{-1} \left[ \frac{\kappa\alpha}{pe} - \frac{1}{e} \right] \quad (7)$$

$$Q^* = -\frac{p}{\alpha} \left( W_{-1} \left[ \frac{\kappa\alpha}{pe} - \frac{1}{e} \right] + 1 \right).$$

Equation (7) implies that  $Q^*$  does not exist if an odd number of  $\{p, K, \alpha\}$  are negative, or if there is an even (or zero) number of  $\{p, K, \alpha\}$  are negative and  $V < \frac{e^{\alpha t_r + \beta t_j} K \alpha}{p}$ .

Thus there is a significant structural difference between the approximation given by the Blackburn and Scudder approximation (4) and exact solution in terms of the Lambert W function (7). This highlights the value of exact, analytical solutions.

We emphasize that (7) is an exact analytical solution for the optimal order quantity,  $Q^*$ . Notice that in (7) we have specified the alternative branch to the Lambert W function. This is because we know the optimal order quantity, the deterioration rate, and the picking rate are all positive  $\{Q^*, \alpha, p\} \in \mathbb{R} \geq 0$ . It then follows that  $W[z] < -1$ , which only occurs on  $W_{-1}[z]$ , the alternative branch, see Figure 1.

### 2.1. Practical example

We now compare our exact solution in (7) to the lower bound given by (4). We assume, as did [10], that the following enumeration is relevant: The value of the melons at picking is,  $V = \$7$ , and the deterioration rate at a field temperature of 30°C,  $\alpha = 0.03$  per hour. The batch transfer time,  $t_r = \frac{1}{2}$  hour, the batch transfer cost,  $K = \$75$ , the time in the cold chain,  $t_j = 5$  days, and the deterioration rate in the cold chain,  $\beta = 0.02$  per day.

Allowing the picking rate to vary between 1 and 120 cartons per hour produces an optimal transfer batch quantity,  $Q^*$ , which is shown in Figure 2, where we have plotted both the lower bound given in [10] and the exact Lambert W-based solution. The lower bound (4) consistently underestimates the true optimal batch quantity ( $Q^*$ ) by 8 to 14 units. This is a significant amount, since a typical picking rate of 40 cartons per hour results. The percentage error,  $\left( (Q^* - Q) / Q^* \right) \times 100\%$ , has also been plotted in Figure 2.

It is also interesting to determine the minimum value of the melons ( $V$ ) required to ensure that an optimal transfer batch quantity,  $Q^*$ , exists in this practical example. Allowing the picking rate,  $p$ , to vary against the deterioration rate at field temperature,  $\alpha$ , the following contour plots can be constructed (when  $K = 75$ ,  $\beta = 0.02$ ,  $t_r = 0.5$ ,  $t_j = 5$ ). Figure 3 confirms that the minimum value of melons required to ensure  $Q^*$  exists increases when the picking rate decreases and when the deterioration rate increases.

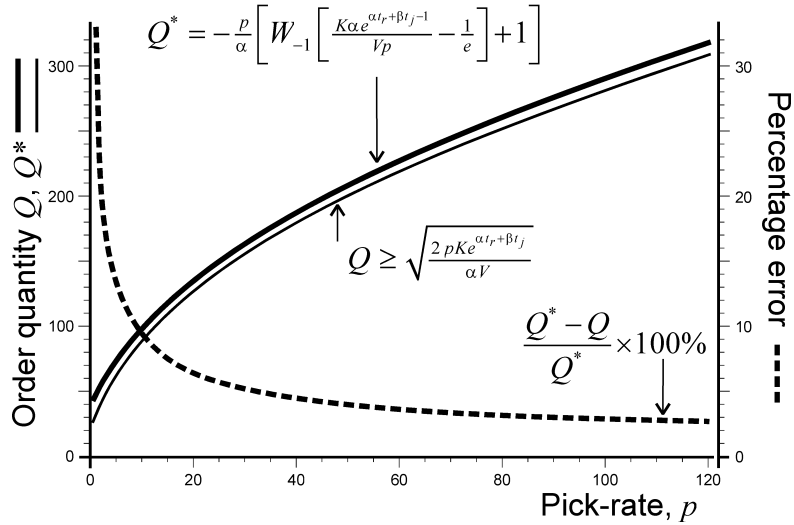

Figure 2. Blackburn and Scudder’s lower bound and the exact Lambert W solution

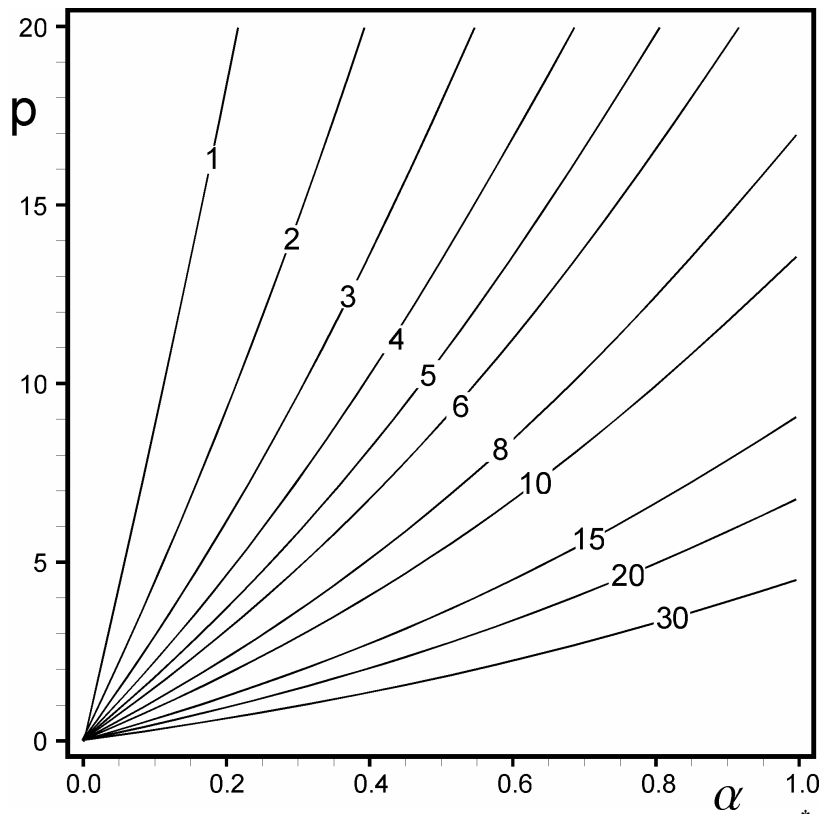

Figure 3. The minimum value of melons ( $V$ ) required to ensure  $Q^*$  exists

**3. Net present value of an EOQ problem with trim loss**

VT Foams Ltd. [11] makes foam for other manufacturers to use inside products, usually furniture or vehicles. Typically, their customers order rolls of foam with specific properties, such as a certain thickness, colour, density, pore size, fire or heat resistance,

and other special characteristics. There are many different types of foam offered for sale by VT Foams, with the number of different types running into the hundreds.

Trucks transport the chemicals used to make the foam to the factory from all over Europe. After they arrive, the volatile chemicals are left to settle in storage tanks for 2-3 days. When they are settled the chemicals are combined and sprayed onto a slowly moving conveyor belt that is 3m wide and 60m long. This process takes about 2 hours. The chemicals react and the foam 'sets'. That is, it rises like a loaf of bread, up to 2m high. There is a crust on the outside, and the top is dome shaped, see Figure 4.

The raw loaf of foam is trimmed and the top is cut off to remove the crust. This produces a uniform block of foam, with a consistent density of holes throughout its volume. This block of foam is then bent into a 'donut' and the ends are bonded together.

The donut is then skimmed (see Figure 4) to create rolls of continuous foam of a certain thickness. The thinner the slice of foam shaved off the donut, the longer the slice is. A 3mm slice will create about 18km of foam from a 2m high loaf. There is about 1km of 3mm foam on a typical roll that is sold to a customer, so that a loaf can supply up to 18 rolls of foam. Customers typically order one roll of foam at a time, the rest are stored as a finished product in a warehouse until they are sold.

The loaf of foam is 60 meters long, and this is a fixed constant. If the loaf is any shorter, the 'donut' cannot be formed as the bend is too tight; and if the loaf is any longer, it will not fit into the skimming machine in the later stage. The width is also fixed as this is the width of the conveyor belt and cannot be changed; it will become the height of the roll that will later be shaved off the donut. However, the height of the loaf is a variable. If demand for the foam variant is high, more chemicals can be sprayed onto the conveyor belt and the height of the loaf will increase. A higher loaf will produce a longer skim.

The higher the loaf, the smaller the percentage of foam that is trimmed to create the uniform block. In a 2m high loaf, about 20% of the material cost is due to the wastage from the trimming activities. However, if a 1m high loaf is made, 40% of the material is lost in the trimming. The material cost is about 60% of the final cost of the product. The amount of waste trimmed off the loaf to create the block is assumed to be a constant, regardless of the height of the loaf. Obviously, the department that makes the loaf wants to minimise this waste by making loafs as high as possible. However, this creates more finished goods to store later in the process (higher loafs create more rolls of foam in inventory). This conflict results in the classic Economic Order Quantity trade-off.

Also of interest here is the very long interval between successive batches. It is not uncommon for this company to make a batch that will satisfy a year's worth of customer demand. Given this long time scale, we propose that the NPV of the cash flows should be considered in the EOQ analysis.

### 3.1 EOQ with trim loss

First we will ignore the time value of money and briefly analyse the VT Foams Ltd. case as a classic EOQ problem. Let  $TC$  be the total annual cost to be minimised by changing



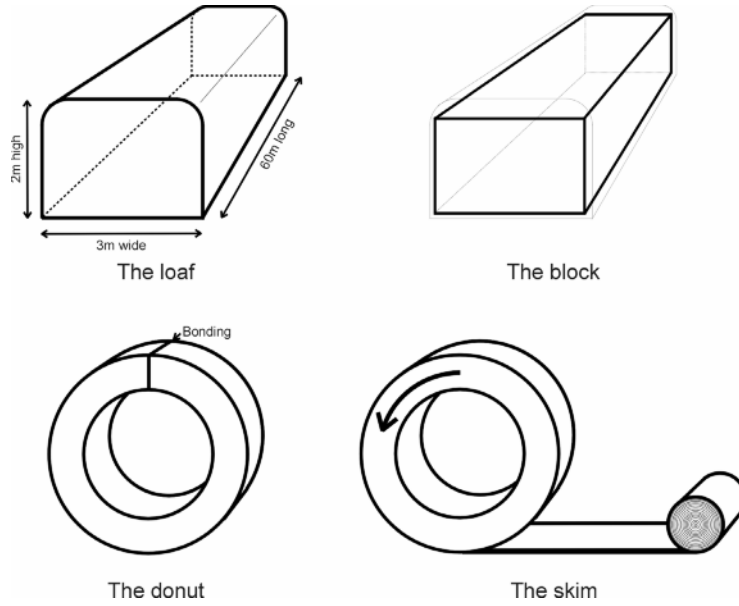

**Figure 4. Making rolls of foam: The loaf, block, donut and skim**

$Q$ , where  $Q$  is directly linked to the height of the loaf, the decision variable in this case.  $D$  is the annual demand for rolls of the foam variant, and  $h$  is the annual inventory holding (storage) cost per roll.  $k$  is the production set-up cost associated with the loaf, block, donut and the  $Q$  rolls.  $y$  is the cost of the lost yield due to the trimming of the loaf to create the uniform block.  $c$  is the direct cost to produce a unit of the foam (not including the holding, trim loss or order placement and set-up cost).

Under the usual assumptions for EOQ models, (see Hopp and Spearman [12] for a concise list that are also relevant here), the average inventory holding over the whole year is  $Q/2$  and the average number of replenishment orders per year is  $D/Q$ . Hence, the annual direct cost is given by  $Dc$ , the annual inventory cost is  $Qh/2$ , the annual set-up cost is  $Dk/Q$  and the annual cost of yield loss from the trimming is  $Dy/Q$ . Thus the annual costs are given by

$$\text{Total Annual Costs } (TC) = Dc + \frac{Qh}{2} + \frac{D}{Q}(k + y). \quad (8)$$

Differentiating (8) with respect to  $Q$  yields  $\frac{dTC}{dQ} = \frac{h}{2} - \frac{D(k+y)}{Q^2}$ . Setting  $(dTC/dQ) = 0$  and solving for the positive root yields the optimal value of  $Q$ ,  $Q^*$ , which is

$$Q^* = \sqrt{2D(k+y)/h}. \quad (9)$$

It is easy to show that the second derivative of (8) is always positive for relevant parameter settings, and so (9) is a minimum. Therefore, as the optimal height of the loaf

is related to  $Q$ , the loaf height optimisation is simply an EOQ problem, where the cost of the trimming is incorporated into the set-up cost of the traditional EOQ problem.

### 3.2. NPV of the cash flows in the EOQ with trim loss problem

Let  $NPV_{EOQ}$  be the NPV of the cash flows resulting from the EOQ decision for a particular product variety of foam. Our objective is to maximise  $NPV_{EOQ}$  by changing  $Q$ . All notations and assumptions from above also hold here. The production orders are placed  $Q/D$  periods apart and the inventory levels fall linearly by  $D$  per period of time. Using the Laplace transform and some rather basic control engineering knowledge (see Nise [13], or Buck and Hill [14]) we may develop the block diagram in Figure 5 to describe the cash flows in this EOQ system. The use of the Laplace transform to capture this information is possible as the NPV of a cash flow over time,  $f(t)$  is given by its Laplace transform,  $F(s)$ , where the Laplace operator,  $s$ , has been replaced by the continuous discount rate,  $r$ , Grubbström [15].

$$NPV = \left[ F(s) = \int_0^{\infty} e^{-st} f(t) dt \right]_{s=r}. \quad (10)$$

The Laplace transform approach is rather scalable as complex cash flows can be easily handled. In order to be able to exploit it, we recommend a block diagram approach as the necessary equations can be readily obtained graphically. In Figure 5 we have used: the impulse response  $\delta$  for the standard input that drives the whole system, and the integrator  $s^{-1}$  to convert the impulse into a unit step, that has been scaled by  $pD$  to represent the sales cash flow. The feedback loop  $(1 - e^{-Qs/D})^{-1}$  converts the single impulse response into a sequence of repeating impulse responses that occur  $Q/D$  periods apart. These are scaled by  $(k + y + cQ)$  to represent the order cost cash flow.

The inventory cost cash flow uses the ramp function  $s^{-2}$  with a slope is  $D$ , a repeating impulse generated by the feedback loop  $(1 - e^{-Qs/D})^{-1}$ , which is then converted into a "staircase" by the integrator  $s^{-1}$ , where each step is scaled by  $Q$ . The scaled ramp and scaled staircase are then joined and scaled by  $h$  to generate the inventory holding cost cash flow. The three flows can then be combined to give the complete cash flow of the EOQ model. Figure 6 gives an illustration of the individual signals that make up the NPV.

Consider now each of the three cash flows in turn. Using standard block diagram manipulation techniques, we can determine the relationship between the sales cash flow and the unit impulse, Dirac delta function,  $\delta$ . The Laplace transform of the sales cash flow is given by  $pD/s$ . Setting the Laplace operator ( $s$ ) to the discount rate yields the PV of the sales

$$PV_{\text{Sales}} = \frac{pD}{s}. \quad (11)$$

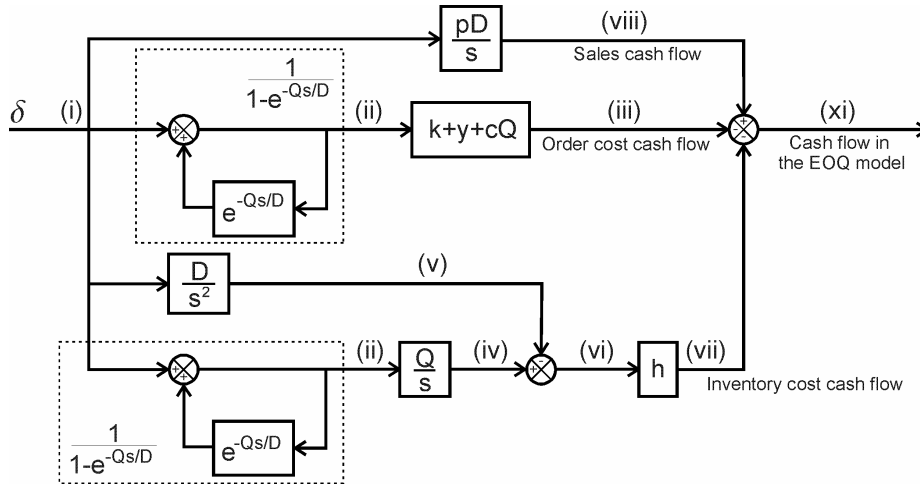

**Figure 5. Block diagram of the cash flows in the EOQ with trim loss model**

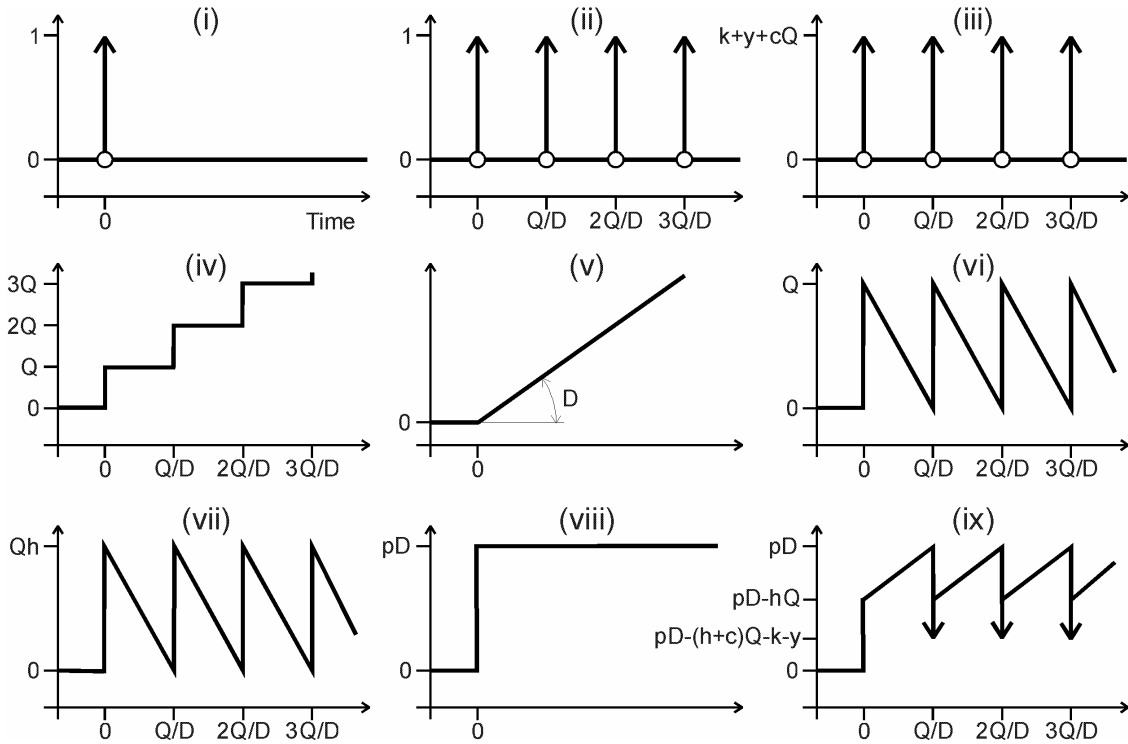

**Figure 6. Signals that constitute the cash flows generated by the EOQ model**

The PV of the order costs can also be determined from the block diagram, which is

$$PV_{\text{Order Cost}} = \frac{k+y+cQ}{1-e^{-Qs/D}} \quad (12)$$

In a similar manner we can also obtain the PV function of the inventory cost cash flow,

$$PV_{\text{Inventory Cost}} = \frac{Qh}{s(1-e^{-Qs/D})} + \frac{Dh}{s^2}. \quad (13)$$

The NPV of all three cash flows in the EOQ model is then given by

$$NPV_{EOQ} = \frac{pD}{s} - \frac{k+y+cQ}{1-e^{-Qs/D}} - \frac{hQ}{(1-e^{-Qs/D})s} - \frac{Dh}{s^2}. \quad (14)$$

Differentiating (14) w.r.t.  $Q$  yields,

$$\frac{dNPV_{EOQ}}{dQ} = \frac{e^{-Qs/D} (D(h+cs) + (k+y)s^2 + Qs(h+cs)) - D(h+cs)}{Ds(e^{-2Qs/D} - 2e^{-Qs/D} + 1)}, \quad (15)$$

where it is easy to see that the stationary points are at

$$e^{-Qs/D} (Qs(h+cs) + D(h+cs) + (k+y)s^2) = D(h+cs). \quad (16)$$

Multiplying by  $-(D(h+cs))^{-1}$  gives

$$e^{-Qs/D} \left( -\frac{Qs}{D} - 1 - \frac{(k+y)s^2}{D(h+cs)} \right) = -1. \quad (17)$$

Finally, multiplying by  $e^{-1-\frac{(k+y)s^2}{D(h+cs)}}$  formats the stationary point into the required Lambert W form,

$$\left( -\frac{Qs}{D} - 1 - \frac{(k+y)s^2}{D(h+cs)} \right) e^{-\frac{Qs}{D} - 1 - \frac{(k+y)s^2}{D(h+cs)}} = -e^{-1-\frac{(k+y)s^2}{D(h+cs)}}, \quad (18)$$

where can now identify the following 'W' terms,

$$W[z] = \left( -\frac{Qs}{D} - 1 - \frac{(k+y)s^2}{D(h+cs)} \right); \quad z = -e^{-1-\frac{(k+y)s^2}{D(h+cs)}}. \quad (19)$$

Re-arranging Equation (19) for  $Q^*$  yields

$$Q^* = \frac{-(k+y)s}{(h+cs)} - \frac{D}{s} \left( 1 + W_{-1} \left[ -e^{-1-\frac{(k+y)s^2}{D(h+cs)}} \right] \right). \quad (20)$$

In (20) we have selected the alternative branch of the Lambert W function. Note that in our problem  $\{k, y, c, s, h, D, Q^*\} \in \mathbb{R} \geq 0$ , which implies that  $W[z] < -1$ ;  $z = -e^{-1-\frac{(k+y)s^2}{D(h+cs)}}$ .

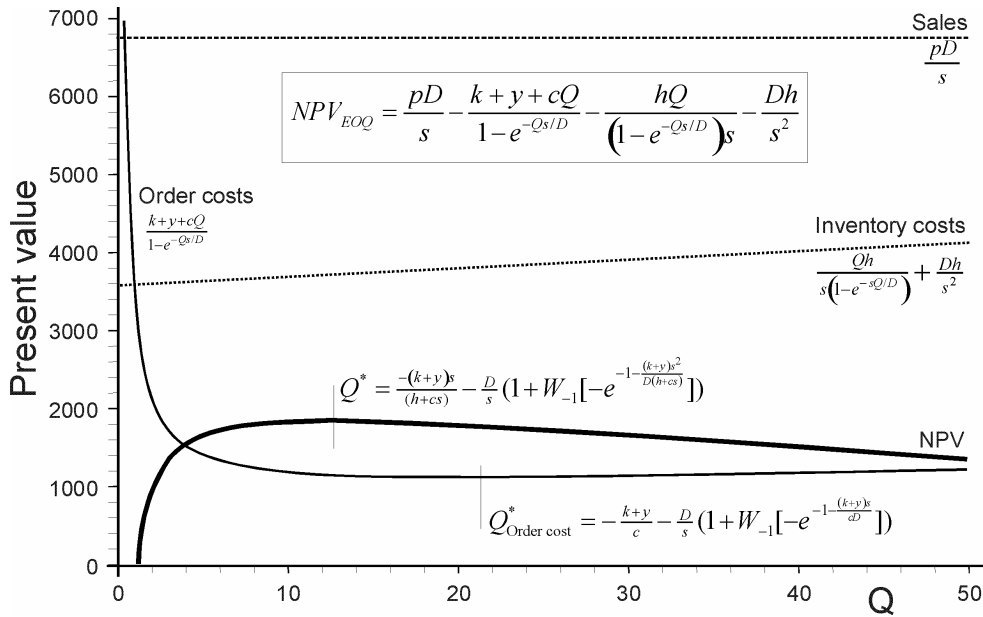

**Figure 7. Net present value costs in the EOQ with trim loss against the batch size  $Q$**

Now the exponential term  $-e^{-1} \leq z \leq 0$ , which in turn means that  $W[z] < -1$  will only happen if the alternative branch is selected, and hence our choice in (20).

The NPV and the three individual costs have been plotted as a function of  $Q$  in Figure 7. The curves refer to the practically relevant case of sales price  $p = 75$ , demand  $D = 18$ , discount rate  $s = 0.2$ , order placement cost  $k = 25$ , direct (variable) order cost  $c = 10$ , trim loss per order  $y = 2$ , and inventory holding cost  $h = 4$ . Interestingly, when the individual cash flows are considered, there is even a minimum in the order costs, a result that was also found by [8]. This did not happen in the classical EOQ approach. We refer interested readers to Appendix 1 for the optimal  $Q$  that minimises the order cost function - a rather easy result with the approach we have followed here. While the inventory cost NPV curve looks linear as plotted in Figure 7, it is in fact a curve. Its derivative is  $(h/2s)$  at  $Q = 0$  and  $h/2$  at  $Q = \infty$ . The NPV can be shown to be positive if (21) holds.

$$\frac{D}{s} \left( \frac{ps-h}{h+cs} + W_{-1}[z] \right) - \frac{s(k+y)}{h+cs} < Q < \frac{D}{s} \left( \frac{ps-h}{h+cs} + W_0[z] \right) - \frac{s(k+y)}{h+cs}; \quad z = \frac{h-ps}{h+cs} e^{\frac{D(h-ps)+s^2(k+y)}{D(h+cs)}} \quad (21)$$

Finally, we note that even though the NPV curve implies that small deviations in  $Q^*$  will not result in a significant loss in NPV, the batch size given by the classic EOQ formula is  $Q^*_{\text{Classical}} = 31.82$ , whilst that provided by the NPV EOQ approach is  $Q^*_{\text{NPV}} = 12.44$ . This implies that the VT Foams should reduce its batch size by 60% and produce more frequently. The NPV of producing with  $Q = 12$  is £1,849.70, and with  $Q = 31$  is

£1,665.70. The smaller batch size improves the NPV by 10%. Given the number of batches produced per year this is a significant cost difference.

#### 4. Pedagogical considerations

In order to arrive at these exact solutions we did not have to change anything in the way we set up the equations. It was only at the point of solving the equation did the ‘Lambert W’ function emerge. We merely had to manipulate the equations, and the most difficult aspect of that is to recall how to treat exponential functions. This should be easily achievable by postgraduate students after a short refresher, see Table 1. The other slight complication is the selection of the relevant branch of the Lambert W function. In essence however, it is no more complicated or abstract than selecting the positive square root in the classic EOQ procedure. Indeed, selecting the wrong branch will result in a negative  $Q$ , prompting one to consider the other branch.

The Lambert W function does however require calculation. Whilst this is easy to do in specialist mathematical software such as Maple or Mathematica, student access to this software is rather limited. In order to overcome this in a classroom setting, we have provided a ‘look-up’ table for the real solutions to the Lambert W function in Appendix 2. This may be printed out by interested readers and become part of their teaching materials. It is intuitive and no more difficult to use than the standard normal table used in many operations management / industrial engineering texts.

It is interesting to note that in the region  $-0.36 \leq z \leq -0.01$ , a Lagrange Interpolating Polynomial with four data points (two above and two below  $z$  as given in Table 3 provides an approximation with less than 0.09% error of the true value of the Lambert W function of the alternative branch, and less than 0.054% error on the principle branch. Additionally, for the principle branch, in the region  $-0.1 \leq z \leq 0.73$ , the error is less than 0.00052%; in the region  $0.7 \leq z \leq 4.4$  the error is less than 0.00004%; and in the region  $4.5 \leq z \leq 22.5$ , the error is less than 0.000032%.

However, a much more useful iterative procedure for determining the real solutions to the Lambert W function has been proposed by Johnson [16], see (22). It is based on Newton’s Method and converges rather quickly (usually within 5-10 iterations, so there is no need to do many iterations).

|  |   |  |
|--|---|--|
| $e^0 = 1$                                    | $e^{-x} = \frac{1}{e^x}$  | Each value of $x$ determines a unique value of $e^x$ |
| $e^1 \approx 2.718281828459045$              | $e^x \times e^y = e^{x+y} \quad \forall \{x, y\} \in \mathbb{R}$          | If $x > y$ then $e^x > e^y$                          |
| $\lim_{x \rightarrow \infty} [e^x] = \infty$ | $(e^x)^k = e^{xk} \quad \forall x \in \mathbb{R} \ \& \ k \in \mathbb{Z}$ | $\frac{d(e^x)}{dx} = e^x$                            |
| $\lim_{x \rightarrow -\infty} [e^x] = 0_+$   | $e^x > 0 \quad \forall x \in \mathbb{R}$                                  | $e^{i\pi} = -1$                                      |

**Table 1. Properties of the exponential function**

$$w_{i+1} = \frac{ze^{-w_i} + w_i^2}{w_i + 1}; W[z] = \lim_{i \rightarrow \infty} w_i \quad (22)$$

The principle branch,  $W_0[z]$ , can be found by using  $w_0 = 0$  when  $-e^{-1} \leq z \leq 10$ , when  $z > 10$  use  $w_0 = \ln[z] - \ln[\ln[z]]$ . For the alternative branch,  $W_{-1}[z]$ , use  $w_0 = -2$  if  $-e^{-1} \leq z \leq -0.1$  or  $w_0 = \ln[-z] - \ln[-\ln[-z]]$  if  $0.1 \leq z < 0$ . [16] also proposes another iterative procedure (see (23)) for use when  $z$  is near  $-e^{-1}$  that converges more rapidly than (22).

$$w_{i+1} = -1 + (w_i + 1) \sqrt{\frac{z + e^{-1}}{w_i e^{w_i} + e^{-1}}}; W[z] = \lim_{i \rightarrow \infty} w_i \quad (23)$$

Here the principle branch,  $W_0[z]$ , can be found by using  $w_0 = 0$ . For the alternative branch,  $W_{-1}[z]$ , use  $w_0 = -2$ . It is a trivial matter to incorporate both of these iterative procedures into a User Defined Function in Microsoft Excel. The Visual Basic code is shown below in Table 2, and provides both the  $W_0[z]$  and  $W_{-1}[z]$  branches. This can be saved as a 'Microsoft Excel Add-In'. After such a procedure is undertaken, then "`=LambertW(mode,z)`" can be used in Microsoft Excel to calculate the Lambert W Function.

## 5. Conclusions

We made a small, but we believe important, contribution to Blackburn and Scudder's [10] EOQ problem with perishable inventory by improving upon their lower bound for the optimum order quantity. We accomplished this by exploiting the properties of the Lambert W function. Recognising that the Lambert W Function is also useful for other EOQ problems with exponential terms, we have illustrated a rather general approach that exploits the Laplace transform to optimise the NPV of an EOQ problem with trim loss. The relation between the Laplace transform and the Lambert W function emerged as an interesting feature. The parallelism between these two functions was first pointed out in [17].

Both of our EOQ problems were motivated by real-world scenarios. Acknowledging that the Lambert W function is not well known, we have provided two pedagogical tools for the operations management and industrial engineering teacher. One is a standard 'look-up' table for class-room use, the other a Microsoft Excel 'Add-In' for self study and professional purposes. Together these tools make the 'Lambert W' solutions no more difficult to use and teach than other inventory problems. Certainly they are no more difficult than a normal distribution table, which is ubiquitous in operations management texts.

```

Function LambertW(mode As Integer, z As Double)
Dim Wo As Double
Dim Wnew As Double

Wnew = 0
If mode = 0 Then
    If z > 10 Then
        Wo = Wo = Log(z) / Log(2.718281828459045) - Log(Log(z) / Log(2.718281828459045)) / Log(2.718281828459045)
    Else
        Wo = 0
    End If
Else
    If z < -0.1 Then
        Wo = -2
    Else
        Wo = Log(-z) / Log(2.718281828459045) - Log(-Log(-z) / Log(2.718281828459045)) / Log(2.718281828459045)
    End If
End If

If z < -0.35 Then
    For grandloop = 1 To 10000
        Wnew = -1+(Wo+1) * ((z+(1/ Exp(1))) / (Wo*Exp(Wo) + (1/Exp(1))))^ 0.5
        If Wo = Wnew Then
            grandloop = 10000
        Else
            Wo = Wnew
        End If
    Next grandloop
Else
    For grandloop = 1 To 10000
        Wnew = ((z * Exp(-Wo)) + Wo ^ 2) / (Wo + 1)
        If Wo = Wnew Then
            grandloop = 10000
        Else
            Wo = Wnew
        End If
    Next grandloop
End If

LambertW = Wnew
End Function

```

**Table 2. Visual Basic Code to calculate the real solutions to the Lambert W function**

## 6. References

1. [http://en.wikipedia.org/wiki/Lambert\\_W\\_function](http://en.wikipedia.org/wiki/Lambert_W_function). Verified 12/12/09.
2. Corless, R.M., Gonnet, G.H., Hare, D.G., Jeffrey, D.J. and Knuth, D.E., 1996. On the Lambert W Function. *Advances in Computational Mathematics*, 5, 329-359.
3. Wright, E.M., 1949. Solution of the equation  $ze^z = a$ . *Proceedings of the Royal Society of Edinburgh* 65, 193-203.
4. Warburton, R.D.H., Disney, S.M., Towill, D.R. and Hodgson, J.P.E., 2004. Further insights into "The stability of supply chains". *International Journal of Production Research*, 42 (3), 639-648.
5. Warburton, R.D.H., 2004. An exact solution to the production inventory control system. *International Journal of Production Economics*. 92 (1), 81-96.
6. Warburton, R.D.H. and Disney, S.M., 2007. Order and inventory variance amplifications: The equivalence of discrete and continuous time analysis. *International Journal of Production Economics*. 110, 128-137.



7. Disney, S.M. and Grubbström, R.W., 2004. The economic consequences of a production and inventory control policy. *International Journal of Production Research*. 42 (17), 3419 – 3431.
8. Warburton, R.D.H., 2009. EOQ extensions exploiting the Lambert W function. *European Journal of Industrial Engineering*, 3 (1), 45-69.
9. Harris, F.W., 1913. How many parts to make at once. *Factory. The Magazine of Management*, 10 (2), 135-136, 152. Reprinted in *Operations Research*, 38 (6), 947-950.
10. Blackburn, J. and Scudder, G., 2009. Supply chain strategies for perishable products: The case of fresh produce. *Production and Operations Management*, 18 (2), 127-137.
11. Disney, S.M., 2007. Making rolls of foam is an EOQ problem: The case of VT Foams Ltd. *MBA / MSc Operations Management Lecture Notes*, Cardiff Business School.
12. Hopp, W.J. and Spearman, M.L., 2000. *Factory Physics: Foundations of Manufacturing Management*, Mcgraw-Hill, Singapore.
13. Nise, N.S., 1995. *Control Systems Engineering*. Benjamin Cummings, Redwood City, CA.
14. Buck, J.R. and Hill, T.W., 1971. Laplace transforms for the economic analysis of deterministic problems in engineering. *The Engineering Economist*, 16 (4), 247-263.
15. Grubbström, R.W., 1967. On the application of the Laplace transform to certain economic problems. *Management Science*, 13 (7), 558-567.
16. Johnson, B., 2009. "Computing LambertW", [www.whim.org/nebula/math/lambertw.html](http://www.whim.org/nebula/math/lambertw.html). Verified 8 October 2009.
17. Warburton, R.D.H., 2004. An analytical investigation of the bullwhip effect. *Production and Operations Management*. 13 (2), 150-160.

### Appendix 1: The optimal order quantity to minimise the present value of the order costs

The present value of the order costs is given by (12). Differentiating w.r.t.  $Q$  yields,

$$\frac{dPV_{\text{Order Cost}}}{dQ} = \frac{e^{\frac{Qs}{D}} \left( cDe^{\frac{Qs}{D}} - c(D + Qs) - s(k + y) \right)}{D \left( e^{\frac{Qs}{D}} - 1 \right)^2} \quad (24)$$

where we can see that there is a stationary point at

$$cDe^{\frac{Qs}{D}} - c(D + Qs) - s(k + y) = 0. \quad (25)$$

Dividing throughout by  $e^{\frac{Qs}{D}}$  and collecting together the  $e^{-\frac{Qs}{D}}$  terms produces,

$$e^{-\frac{Qs}{D}} \left( c(D + Qs) + s(k + y) \right) = cD. \quad (26)$$

Dividing throughout by  $-cD$  yields

$$e^{-\frac{Qs}{D}} \left( -1 - \frac{ks}{cD} - \frac{Qs}{D} - \frac{sy}{cD} \right) = -1 \quad (27)$$

and multiplying by  $e^{-1-\frac{s(k+y)}{cD}}$  yields the required format to read directly the Lambert W terms,

$$e^{-1-\frac{s(k+y+cQ)}{cD}} \left( -1 - \frac{s(k+y+cQ)}{cD} \right) = -e^{-1-\frac{s(k+y)}{cD}} \quad (28)$$

which are

$$W[z] = -1 - \frac{s(k+y+cD)}{cD}; \quad z = -e^{-1-\frac{s(k+y)}{cD}} \quad (29)$$

Then we re-arrange (29) to yield  $Q_{\text{Order Cost}}^*$ , the optimal transfer batch quantity to minimise the present value of the order costs.

$$Q_{\text{Order Cost}}^* = -\frac{k+y}{c} - \frac{D}{s} \left( 1 + W_{-1} \left[ -e^{-1-\frac{s(k+y)}{cD}} \right] \right) \quad (30)$$

Note, in (30) we have selected the alternative branch of the Lambert W function as we can see the 'W' term has to be negative to ensure  $Q_{\text{Order Cost}}^*$  is positive.

## Appendix 2: The real solutions to the Lambert W function

Numerical solutions for  $W_{-1}[z]$  and  $W_0[z]$  are provided in Table 3.

| $z$             | $W_{-1}[z]$ | $W_0[z]$ | $z$  | $W_0[z]$ | $z$  | $W_0[z]$ | $z$   | $W_0[z]$ |
|-----------------|-------------|----------|------|----------|------|----------|-------|----------|
| -1/e = -0.36788 | -1          | -1       | 0.01 | 0.009901 | 0.8  | 0.490068 | 4.5   | 1.267237 |
| -0.365          | -1.13066    | -0.87982 | 0.02 | 0.019612 | 0.85 | 0.510279 | 4.75  | 1.297615 |
| -0.36           | -1.22277    | -0.80608 | 0.03 | 0.029138 | 0.9  | 0.529833 | 5     | 1.326724 |
| -0.355          | -1.29124    | -0.75624 | 0.04 | 0.03849  | 0.95 | 0.548774 | 5.25  | 1.354670 |
| -0.35           | -1.34972    | -0.71664 | 0.05 | 0.047672 | 1    | 0.567143 | 5.5   | 1.381545 |
| -0.345          | -1.40239    | -0.68311 | 0.06 | 0.056693 | 1.05 | 0.584975 | 5.75  | 1.407432 |
| -0.34           | -1.4512     | -0.65369 | 0.07 | 0.065558 | 1.1  | 0.602304 | 6     | 1.432404 |
| -0.335          | -1.49726    | -0.62731 | 0.08 | 0.074273 | 1.15 | 0.619158 | 6.25  | 1.456526 |
| -0.33           | -1.54127    | -0.60327 | 0.09 | 0.082844 | 1.2  | 0.635564 | 6.5   | 1.479856 |
| -0.325          | -1.58368    | -0.5811  | 0.1  | 0.091277 | 1.25 | 0.651548 | 6.75  | 1.502447 |
| -0.32           | -1.62485    | -0.56049 | 0.11 | 0.099574 | 1.3  | 0.667132 | 7     | 1.524345 |
| -0.315          | -1.66502    | -0.54118 | 0.12 | 0.107743 | 1.35 | 0.682337 | 7.25  | 1.545593 |
| -0.31           | -1.70439    | -0.52299 | 0.13 | 0.115786 | 1.4  | 0.697182 | 7.5   | 1.566230 |
| -0.305          | -1.74312    | -0.50577 | 0.14 | 0.123709 | 1.45 | 0.711684 | 7.75  | 1.586292 |
| -0.3            | -1.78134    | -0.4894  | 0.15 | 0.131515 | 1.5  | 0.725861 | 8     | 1.605811 |
| -0.295          | -1.81915    | -0.47379 | 0.16 | 0.139208 | 1.55 | 0.739728 | 8.25  | 1.624817 |
| -0.29           | -1.85665    | -0.45886 | 0.17 | 0.146791 | 1.6  | 0.753298 | 8.5   | 1.643337 |
| -0.285          | -1.89391    | -0.44453 | 0.18 | 0.154268 | 1.65 | 0.766585 | 8.75  | 1.661395 |
| -0.28           | -1.93101    | -0.43076 | 0.19 | 0.161642 | 1.7  | 0.779601 | 9     | 1.679016 |
| -0.275          | -1.968      | -0.41749 | 0.2  | 0.168916 | 1.75 | 0.792358 | 9.25  | 1.696220 |
| -0.27           | -2.00495    | -0.40468 | 0.21 | 0.176093 | 1.8  | 0.804866 | 9.5   | 1.713028 |
| -0.265          | -2.04191    | -0.3923  | 0.22 | 0.183177 | 1.85 | 0.817136 | 9.75  | 1.729458 |
| -0.26           | -2.07892    | -0.38031 | 0.23 | 0.190169 | 1.9  | 0.829176 | 10    | 1.745528 |
| -0.255          | -2.11604    | -0.36869 | 0.24 | 0.197072 | 1.95 | 0.840997 | 10.25 | 1.761252 |
| -0.25           | -2.15329    | -0.3574  | 0.25 | 0.203888 | 2    | 0.852606 | 10.5  | 1.776647 |
| -0.245          | -2.19073    | -0.34643 | 0.26 | 0.210621 | 2.05 | 0.86401  | 10.75 | 1.791726 |
| -0.24           | -2.2284     | -0.33576 | 0.27 | 0.217272 | 2.1  | 0.875219 | 11    | 1.806502 |
| -0.235          | -2.26633    | -0.32537 | 0.28 | 0.223843 | 2.15 | 0.886238 | 11.25 | 1.820988 |
| -0.23           | -2.30457    | -0.31523 | 0.29 | 0.230337 | 2.2  | 0.897074 | 11.5  | 1.835195 |
| -0.225          | -2.34315    | -0.30535 | 0.3  | 0.236755 | 2.25 | 0.907734 | 11.75 | 1.849135 |
| -0.22           | -2.38212    | -0.29569 | 0.31 | 0.2431   | 2.3  | 0.918224 | 12    | 1.862816 |
| -0.215          | -2.42151    | -0.28626 | 0.32 | 0.249373 | 2.35 | 0.928548 | 12.25 | 1.876250 |
| -0.21           | -2.46136    | -0.27703 | 0.33 | 0.255675 | 2.4  | 0.938714 | 12.5  | 1.889445 |
| -0.205          | -2.50173    | -0.26801 | 0.34 | 0.26171  | 2.45 | 0.948725 | 12.75 | 1.902409 |
| -0.2            | -2.54264    | -0.25917 | 0.35 | 0.267777 | 2.5  | 0.958586 | 13    | 1.915152 |
| -0.195          | -2.58415    | -0.25051 | 0.36 | 0.27378  | 2.55 | 0.968303 | 13.25 | 1.927680 |
| -0.19           | -2.62631    | -0.24203 | 0.37 | 0.279719 | 2.6  | 0.97788  | 13.5  | 1.940001 |
| -0.185          | -2.66917    | -0.23371 | 0.38 | 0.285595 | 2.65 | 0.98732  | 13.75 | 1.952121 |
| -0.18           | -2.71277    | -0.22554 | 0.39 | 0.291411 | 2.7  | 0.996629 | 14    | 1.964049 |
| -0.175          | -2.75718    | -0.21752 | 0.4  | 0.297168 | 2.75 | 1.005809 | 14.25 | 1.975789 |
| -0.17           | -2.80245    | -0.20965 | 0.41 | 0.302866 | 2.8  | 1.014864 | 14.5  | 1.987347 |
| -0.165          | -2.84866    | -0.20192 | 0.42 | 0.308508 | 2.85 | 1.023799 | 14.75 | 1.998730 |
| -0.16           | -2.89587    | -0.19432 | 0.43 | 0.314094 | 2.9  | 1.032616 | 15    | 2.009943 |
| -0.155          | -2.94415    | -0.18684 | 0.44 | 0.319625 | 2.95 | 1.041318 | 15.25 | 2.020991 |
| -0.15           | -2.99359    | -0.17949 | 0.45 | 0.325104 | 3    | 1.049909 | 15.5  | 2.031879 |
| -0.145          | -3.04429    | -0.17226 | 0.46 | 0.33053  | 3.05 | 1.058391 | 15.75 | 2.042611 |
| -0.14           | -3.09633    | -0.16514 | 0.47 | 0.335905 | 3.1  | 1.066768 | 16    | 2.053192 |
| -0.135          | -3.14983    | -0.15813 | 0.48 | 0.34123  | 3.15 | 1.075042 | 16.25 | 2.063627 |
| -0.13           | -3.2049     | -0.15122 | 0.49 | 0.346506 | 3.2  | 1.083216 | 16.5  | 2.073919 |
| -0.125          | -3.26169    | -0.14442 | 0.5  | 0.351734 | 3.25 | 1.091292 | 16.75 | 2.084073 |
| -0.12           | -3.32033    | -0.13772 | 0.51 | 0.356914 | 3.3  | 1.099273 | 17    | 2.094092 |
| -0.115          | -3.38099    | -0.13111 | 0.52 | 0.362049 | 3.35 | 1.107161 | 17.25 | 2.103980 |
| -0.11           | -3.44387    | -0.1246  | 0.53 | 0.367138 | 3.4  | 1.114958 | 17.5  | 2.113741 |
| -0.105          | -3.50918    | -0.11817 | 0.54 | 0.372183 | 3.45 | 1.122667 | 17.75 | 2.123377 |
| -0.1            | -3.57715    | -0.11183 | 0.55 | 0.377184 | 3.5  | 1.130289 | 18    | 2.132892 |
| -0.095          | -3.64808    | -0.10558 | 0.56 | 0.382143 | 3.55 | 1.137827 | 18.25 | 2.142289 |
| -0.09           | -3.72228    | -0.09941 | 0.57 | 0.387059 | 3.6  | 1.145283 | 18.5  | 2.151571 |
| -0.085          | -3.80014    | -0.09331 | 0.58 | 0.391934 | 3.65 | 1.152657 | 18.75 | 2.160742 |
| -0.08           | -3.88211    | -0.0873  | 0.59 | 0.396769 | 3.7  | 1.159953 | 19    | 2.169802 |
| -0.075          | -3.96871    | -0.08136 | 0.6  | 0.401564 | 3.75 | 1.167172 | 19.25 | 2.178756 |
| -0.07           | -4.06059    | -0.07549 | 0.61 | 0.406319 | 3.8  | 1.174316 | 19.5  | 2.187606 |
| -0.065          | -4.15853    | -0.06969 | 0.62 | 0.411037 | 3.85 | 1.181385 | 19.75 | 2.196354 |
| -0.06           | -4.2635     | -0.06396 | 0.63 | 0.415716 | 3.9  | 1.188383 | 20    | 2.205003 |
| -0.055          | -4.37672    | -0.0583  | 0.64 | 0.420359 | 3.95 | 1.19531  | 20.25 | 2.213554 |
| -0.05           | -4.49976    | -0.05271 | 0.65 | 0.424965 | 4    | 1.202168 | 20.5  | 2.222011 |
| -0.045          | -4.63465    | -0.04717 | 0.66 | 0.429535 | 4.05 | 1.208958 | 20.75 | 2.230376 |
| -0.04           | -4.78419    | -0.0417  | 0.67 | 0.434071 | 4.1  | 1.215682 | 21    | 2.238649 |
| -0.035          | -4.95225    | -0.03629 | 0.68 | 0.438571 | 4.15 | 1.222341 | 21.25 | 2.246834 |
| -0.03           | -5.14448    | -0.03094 | 0.69 | 0.443037 | 4.2  | 1.228936 | 21.5  | 2.254932 |
| -0.025          | -5.36964    | -0.02565 | 0.7  | 0.44747  | 4.25 | 1.235469 | 21.75 | 2.262946 |
| -0.02           | -5.64232    | -0.02041 | 0.71 | 0.45187  | 4.3  | 1.24194  | 22    | 2.270876 |
| -0.015          | -5.98976    | -0.01523 | 0.72 | 0.456238 | 4.35 | 1.248352 | 22.25 | 2.278725 |
| -0.01           | -6.47278    | -0.0101  | 0.73 | 0.460573 | 4.4  | 1.254704 | 22.5  | 2.286495 |
| -0.005          | -7.284      | -0.00503 | 0.74 | 0.464877 | 4.45 | 1.260999 | 22.75 | 2.294186 |
| 0               | -∞          | 0        | 0.75 | 0.46915  | 4.5  | 1.267238 | 23    | 2.301801 |

Table 3. Enumeration of the real solutions to the Lambert W function