

Novel process for coating textile materials with silver to prepare antimicrobial fabrics

M.S. Sataev ^a, S.T. Koshkarbaeva ^a, A.B. Tleuova ^b, S. Perni ^c, S.B. Aidarova^b, P. Prokopovich^{d,e}

^a South Kazakhstan State University, Shymkent, Kazakhstan

^b Kazakh National Technical University, Almaty, Kazakhstan

^c School of Chemical Engineering, University of Birmingham, Birmingham, UK

^d School of Pharmacy and Pharmaceutical Science, Cardiff University, Cardiff, UK

^e School of Engineering, Cardiff University, Cardiff, UK

* Corresponding author:

Email: prokopovichp@cf.ac.uk

Tel : +44 (0) 29208 75820

School of Pharmacy and Pharmaceutical Science

Cardiff University

Cardiff

CF10 3NB

UK

Abstract

The technology of applying a silver coating on fabric is presented. Tissue is wetted with a solution of copper sulphate, which is then reduced to metal-phosphide by phosphine treatment. Wetting can be carried out by immersing the fabric in a copper sulphate solution or spraying the solution onto the fabric using a sprayer. The subsequent processing step is the immersion of the fabric in a solution of silver nitrate, during this copper phosphide is transformed to a silver coating. The developed technology allows achieving a good grip of the fabric with a continuous silver films with a thickness from 40 to 600 nm. Using copper sulphate spray, coatings consisting of individual dots or clusters of silver were obtained. The silver coated tissues exhibited antimicrobial activity even after 10 washing.

Keywords: silver nanoparticles, antimicrobial coatings, antimicrobial fabric, textile

Introduction

Silver is one of the bactericidal and therapeutic agent that has been used for thousands of years in different parts of the world [1,2]. Because of its multitarget mechanism of action a wide spectrum of bacteria, about 650 species of bacteria, can be inactivated using nanoparticles, whereas the antibacterial spectrum of antibiotics can be quite limited- in some cases, only 5-10 species of bacteria [3-5].

The growth of microorganisms on fabric materials can be problematic, therefore, normally textile products are often treated with antimicrobial agents [6,7]. Currently, applications of bactericidal silver particles on the surface of various fabric materials have been developed for domestic, medical and other purposes [8-11]. These fabrics can be used for the manufacture of medical products (bandages, wounds dressings, surgical thread, etc.) and different types of clothing (military uniforms, sportswear, underwear, etc.) protecting from the risk of infections or avoiding the unwanted outcome of bacteria growth [12,13]. An example of such application is for socks preventing the growth of bacteria resulting in malodor. There is evidence that astronauts of International Space Station fly in space in socks with silver nanoparticles produced in Russia [3,14,15].

Many methods to apply metal films on non-metallic materials have been presented; these can be potentially used for deposition of silver films [16-27]. Among these, the most frequently used is the so-called "physical and chemical methods". In the physical method, previously molten metal particles are sprayed on the coated surface with compressed air or gas. The particles of the liquid metal on the way to the surface are partially cooled and only those with melted surfaces cling to the chosen support. A variation of this method is the vacuum metallization [17-22]. The chemicals employed in this technology are harmless to the environment and personnel. However, for its implementation one should have a relatively sophisticated and expensive apparatus.

When using physical methods of silvering, previously obtained silver nanoparticles are needed, these are then applied by the gas-phase, plasma or vacuum deposition. Disadvantages of the physical methods are difficulties of plating the internal surfaces of porous materials and the complexity of controlling the thickness of the coating.

Another approach for chemical deposition of metal coatings employs reducing agents that are either in the gas phase or dissolved in an electrolyte solution [21-24]. Gaseous hydrogen can be used in reduction reactions performed at high temperatures, in the order of several hundred degrees. In this way, it is possible to obtain coverage from a fairly large number of metals, but the requirement of special equipments for heating and dispensing gas mixtures limits the widespread use of the method.

In metallization in a gas phase a thermal decomposition reaction is often used. The most suitable compounds for this purpose are metal carbonyls. These compounds at room temperature are in the liquid or solid state. When heated above a certain temperature (usually a few hundred degrees) carbonyls decompose to carbon monoxide and metal. Carbon monoxide can again be used to obtain metal carbonyl. In this way CO can be in a closed loop. This is not only useful in industrial applications, but also can be employed to minimize the overhead of auxiliary reagents and to eliminate pollution. The widespread application of this method is hindered by the relatively high temperature of the process and the high cost of metal carbonyls [19, 20].

Chemical-electrolytic plating [17, 25-27] is used to create a conductive surface, the dielectric layer is activated by creating catalytic centers which are then coated by a chemical method. Chemical and electrolytic technologies have limitations associated with the use of expensive materials, the use of high temperature and loss of coating on highly porous materials.

For the application of silver nanoparticles on fabrics a method that combines chemical reduction and physical adsorption by ultrasound has been also proposed [24]. A cotton

sample is placed in a solution of silver nitrate in the presence of aqueous ethylene glycol and ammonium hydroxide, and then it is subjected to ultrasonic treatment. Ethylene glycol is intended to restore the silver to metal, however, as a consequence the formation of a stable complex $[\text{Ag}(\text{NH}_3)_2]^+$ is achieved, silver ions concentration decreases and the reduction reaction is going very slow. In such conditions, the formation of very small particles (nano particles) of silver occurs and the fabric becomes dark yellow, which is difficult to remove even after rigorous washing. A series of washes are required to remove the particles that are not attached to the fabric. Mass fraction of the deposited silver weakly depends on the nature of the fabric indicating that the particles are bound to the tissue by physical adsorption. It has been suggested that ultrasound pressed the particles into the surface of fibers. The average particle size diameter for this process is about 80 nm, but also larger particles are formed. However, this method has some disadvantages, for example the possibility of formation of silver particles not only on the surface of the fabric, but also in the solution; as consequence of the diffusion limitation, the coating in the depths of pores is thinner than in the outer layers, finally, the use of ultrasound leads to complication of technological process.

It is, therefore, evident that the development of alternative methods of metallization of textiles surfaces, which do not require special equipment and expensive reagents, is needed to solve the specific problems associated with the currently available processes.

In this work a novel approach of silver implantation on fabrics is presented. This is a low temperature process based on a gas-phase reaction between phosphine and copper sulphate. Initially the copper phosphide layer was prepared and then it was transformed into silver. The developed method for producing a conductive layer on surfaces allows plating both metal and dielectric materials [28]. This technique is suitable for porous materials as well. The main technological parameters of the process of obtaining phosphide films were studied on the

surfaces of flat metal (copper, nickel) and dielectric plates. This technique is relatively inexpensive and does not require sophisticated equipment.

Materials and Methods

Chemicals

All chemical were purchased by Sigma-Aldrich (Kazakhstan) and were analytical grade.

Apparatus for textile material coating

In order to ensure wetting of the sample surfaces by technological solutions and to create the necessary adhesion, a preliminary etching and cleaning step were performed.

Metal plates were etched in a solution of hydrochloric acid 200 g/l. Fabrics made of polymeric materials etched in concentrated sulfuric acid containing 150 g/l of potassium dichromate for 2-3 seconds. Fabrics made of cotton were not etched, as their surface is rough and has good wetting by technological solution (copper sulfate solution). On the prepared surface a layer of copper salt solution was applied. For this, samples were immersed for some time in a solution of copper sulphate. For smooth plates the immersion time was 10-15 seconds while for the porous samples it was 10-15 minutes. After the samples were removed from the solution they were gently shaken resulting on a thin film of copper salt solution on the surface remained.

Phosphine was produced by acid decomposition of powdered zinc phosphide. Zinc phosphide reacts with acids to produce phosphine and the corresponding salt of zinc according to this reaction:



To obtain phosphine, a laboratory-scale plant was used (Fig. 1) consisting of the following parts:

- a) reaction vessel, a glass tube with a small orifice at the top to allow venting of the gas generated from the reaction zone;
- b) collection vessel - a plastic container to collect phosphine containing gas;
- c) leveling vessel - a vessel filled with water for gas displacement in collecting bag or metallization camera.

The sample of zinc phosphide was placed in the lower part of the vessel 1 and moistened with a small amount water. Then a glass tube was corked and immersed in the receptacle 6 in such a way that the neck of the tube tightly closed the vessel neck. Then, from the intermediate vessel 7, by dint of equalizing vessel 9 into the vessel 6, water was added. A burette 5 was filled with 10% hydrochloric acid, which by dint of faucet 4 was provided in the reaction vessel 1. Generated phosphine increased pressure and the squeezed rubber ring fell into the collection vessel 6, the rubber ring also serves as a valve to prevent water from entering the reaction zone. Water from the collection vessel was forced into the intermediate vessel 7. The amount of water displaced from the collection vessel 6 in the intermediate vessel 7 corresponded to the amount of phosphine formed over time. If necessary, the phosphine containing gas was transferred by pressure in the collecting bag 8, where it was stored until use.

After creating of film of copper salt, the samples were slightly dried at room temperature for 30 – 45 minutes and placed in the metallization chamber, where the salt of metal was converted in phosphide by phosphine containing gas. The scheme of the plant in which the experiments were carried out to obtain copper-phosphorus film is shown in Fig. 2.

Sample 1 was hung to cover 2 of metallization chamber 3, and then air was removed from the chamber by purging with nitrogen. After that, phosphine gas was supplied to the chamber of metallization from a pre-filled vessel 4. To do this, the chamber was filled with some water and then, at closed faucets 7 and 8, the water drained by the level vessel 6 lowering. In this case, a vacuum was created in metallization chamber, which when opened faucet 7 contributed to the inflow of gas into the reaction medium. At the flow of gas the water from level vessel 5 flowed into the vessel 4. Because during the reaction the metallization gas is absorbed, then vacuum was maintained throughout the process. At the end of the reaction, the pressure in the vessels 5 and 4 were aligned, and the flow of water from the vessel 5 in vessel 4 was stopped. This made possible to determine the end of the reaction. After the reaction faucet 6 is closed, the remains of the gas with air were forced through a vessel with a copper sulphate solution 9 and went to purification by passing through the vessel 10.

Copper compounds on the surface of the sample interact with phosphine containing gas (at room temperature) and were converted to copper phosphide. As a result, a dark film of copper phosphide was formed on the surface.

The overall reaction phosphide can be represented by the following equation

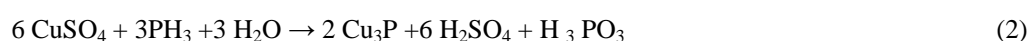

Coating of fabric

Samples of the studied fabrics were soaked in a solution of copper sulphate with concentration of 100-200 g/l and dried at 30-40 °C for 10-20 minutes. Then, the fabric, which was in a slightly moist at this stage, was placed in a sealed chamber and treated by phosphine. Slightly humid conditions of textile are necessary firstly to prevent crystallization of copper

sulfate (that would break the even distribution of the solution layer in some areas of textile) and secondly enhances permeability that is required for the uniform penetration of phosphine through all parts of the fabric.

Thus as a result of reaction 2, on the surface of the fabric, a film, of copper phosphide is form. Then the samples were washed with distilled water to remove by-products of the reaction such as: H_2SO_4 and H_3PO_3 .

For the transformation of copper phosphide in silver, samples were placed for 5-6 hours in a solution containing 1-2 g/l of $AgNO_3$ and 0.5 g/l of HNO_3 . The process of formation of silver is described by the following reactions:

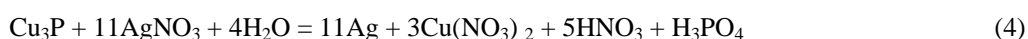
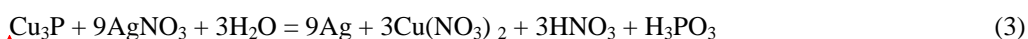

Formatted: Spanish (International Sort)

A slight excess of nitric acid is required to prevent the formation of precipitates due to the interaction of ions of copper and silver with phosphate and phosphite ions.

Coated material testing

A scanning electron microscope, SEM (model ISM-6490-LV, JEOL, Japan) was employed to study of copper-phosphorus films deposited on various surfaces. SEM images of areas (spectra) of the coated surfaces at different magnifications were acquired. The SEM equipment used in the work allows not only to determine the energies or wavelengths emitted spectrum (qualitative analysis), but also to measure the intensity of the lines of the participating elements and, on this basis, perform their quantitative analysis. Therefore, along with the electronic image of the spectrum presents data of the quantitative content of elements in these spectra

To study composition of the copper-phosphorus films X-ray diffractometer, XRD (DRON-3, Russia) in range of angles from 6° to 64° at U = 35 kV, I = 20 mA. was employed.

Film thickness was determined through dielectric wettability [29]. To test the bactericidal properties, the samples of fabrics with embedded silver films and control fabric (without silver films) were placed in a sterile Petri dish and an aqueous solution of agar-agar contaminated with *S. aureus* was poured on the fabric until it was fully covered. The Agar was allowed to cool down and settled with the fabric samples immersed in it, Samples were stored at room temperature and, as a result of microbial growth in the culture medium, colonies of bacteria were noticeable after 5-6 days. The ability of the silver films to prevent bacterial growth was determined through comparison of the number of colonies developed in samples containing coated fabric against controls.

Results

Implantation of silver in textile materials by immersion in copper sulphate solution

The image of the copper phosphide film deposited on a flat nickel plate is presented in Figure 3. It is shown that the film consists of particles of nearly spherical shape with a diameter ranging from 50 nanometers to a few micrometers (Fig. 3). Copper sulfate solution of concentrations from 100 to 250 g/l were applied on a flat metal plate resulting in films of equal thickness (and volume); the thickness of the film of copper phosphide formed after processing with phosphine was proportional to the concentration of copper sulfate increasing from 0.3 to 0.6 microns when copper sulphate concentration increased from 100 to 250 g/l

To study the composition of the films XRD was used. In all obtained X-ray patterns the formation of a film of copper phosphide Cu_3P was observed, which correspond to the diffraction lines with the parameters of the distance between planes of 2.49 \AA , 2.01 \AA , 1.95 \AA and 1.79 \AA . Determination of phosphorus is carried out by molybdate weight method recommended for the analysis of copper phosphide [30]. This revealed that the phosphorus content in the alloy was 10-12%. These data together allows to identify the obtained phosphide as Cu_3P , where the phosphorus content is 12.1%.

Figure 4 shows an electron image of part of the textile that has been treated with a solution $\text{CuSO}_4 - 200 \text{ g/l}$. Table 1 shows that the total silver content in textile is 30% (w/w). The small amount of phosphorus (1.2%) may be associated with the formation of insoluble phosphate or silver phosphate.

Cover was continuous and consisted of clusters of silver particles close to spherical. In some sites located on the outer layers of textile (Fig. 4b, tables 1), silver content was 48%, and 19%.

Bactericidal properties of fabrics having a silver film with thickness of about 40-50 nm obtained after treatment in a solution of $\text{CuSO}_4 - 100 \text{ g/l}$ are presented in Figure 5. For the textile samples without silver coating (sample 1) there was proliferation of *S. aureus* colonies in all parts of the growth medium. For the samples of textile with silver film (sample 2) no colonies were noticeable in proximity of the fabric, although in the rest of the growth medium microorganisms multiply. Bactericidal properties of silver films were retained after 10 washings (sample 3).

Implantation of silver in textile materials by spraying of copper sulphate solution

In some cases, in order to achieve bactericidal properties it is not necessary to produce a continuous film on the surface of the fabric, but it is enough to put the silver particles in some individual sections of textile. For these cases, the process of obtaining the silver particles by spraying was reviewed. The fabric was sprayed with a copper sulfate solution and immediately after this the fabric was treated with phosphine. It was possible to operate without drying, as after spraying, the fabric had sufficient gas permeability. In this approach, the cleaning processes from sulfate and phosphate ions were excluded.

Using this method can significantly reduce the consumption of silver. Thus, if the method is used to pre-silvered dipping in a solution of copper sulfate, the total content of silver in the sample was 30% (Fig. 4), when using spray, this value is 1.2% (Fig. 6). Silver particles were distributed in separate clusters or points. The content of silver in these areas (Fig. 6b), was consistent with its overall content in solid surfaces (Fig. 4).

Fabrics having a silver film prepared through spraying copper sulfate solutions exhibited the same antimicrobial activity of the textile samples prepared through immersion in the copper sulfate solutions (Fig. 5).

Discussion

Etching of metal surfaces was carried out to remove the oxide film, whilst etching of non-metallic surfaces were performed to create microroughness. For porous non-metallic materials or rough surfaces, etching operation is optional.

Deposition of film of copper phosphide on nickel plates was performed to study the composition of the film by X-ray studies and to study the influence the concentration of copper sulfate in the solution in which the sample is immersed to create a layer of the copper sulphate solution in the process of obtaining a film of copper phosphide.

Silver is produced by the interaction of silver ions with copper phosphide. Moreover, almost all copper phosphide is converted into silver. Therefore, the thickness of the silver film is directly associated with the thickness of the film of copper phosphide, which is formed at the initial stage of the process. The thickness of copper phosphide film is dependent on the concentration of copper sulfate in the solution in which the sample is immersed prior exposure to phosphine to create a layer of the copper sulphate solution on the surface.

Also in case of textile materials the thickness of the film of copper phosphide (and consequently of silver) increases with increasing concentrations of copper sulphate but this relationship can not be expressed in terms of proportionally constant for fabric materials because of their significant heterogeneity. Hence, in each case the concentration (or range of concentrations) of antimicrobial film must be determined experimentally.

The proposed method of implantation of silver in textile materials was based on the previously prepared copper phosphide layer, which was then transformed into silver. The process of reception of copper phosphide is a low-temperature gas-phase reaction between phosphine and sulphate of copper.

Moreover, the reaction proceeds through a copper sulfate solution film and with the surface wet, copper sulfate crystals are formed during drying of the film. It is also possible to treat porous materials. In this case, as the outer surface and the inner surface of the pores form a film of wet crystals of copper sulphate, pores become breathable. During the film application on the flat plastic plates, it was observed that if the layer of copper sulphate solution is allowed to dry completely, then on the surface of the plate, crystals of copper sulphate are formed. At the same time, during processing with phosphine, the produced copper phosphide completely retained this structure. At partial drying, uniform film of copper phosphide was form. If the sample is not dried up to a moist condition significantly increases the time required to comprehensively complete the reaction of the formation of copper phosphide as

defined by discontinuation of phosphine absorption. Consequently, as the processing by phosphine reaction of forming of copper phosphorus films takes place on the external and internal surfaces of the porous materials. It contributes to high adhesion of the copper phosphorus film to the textile material. Accordingly, the silver layer, which is formed during the transformation of copper phosphide has the same increased adhesion. This allows the fabric to retain bactericidal after multiple (at least 10 times) washes.

By adjusting the concentration of the solution CuSO_4 in which the sample is wetted sample immersed, the thickness of the resulting metal films can be controlled. Thus, through processing in concentrated solutions film thickness may reach values of 0,5-0,6 microns. Moreover, it is possible to make and further build-up the thickness by chemical or galvanic metallization [28,30]. This allows getting textile products with screening or electrically conductive properties.

Theoretically, by decreasing the concentration of copper sulphate nanosized, silver film can be prepared; however, since they are formed as a result reactions 2, particles of copper phosphide (and later silver particles) have a spherical shape and the minimum thickness of the films obtained by this technology is 40-50 nm.

Applying antibacterial films can be made by spraying a solution of copper sulphate on the surface of the fabric. In this case, the silver particles are formed in some areas in the form of points or clusters. This helps reduce the consumption of silver and to exclude from the technological process the washing and drying operations.

Conclusion

Two methods of silver deposition on fabric materials were presented: in one the textile samples are immersed in a solution of copper sulphate and in another copper sulphate is sprayed of on the textile samples. In both cases, silver particles formed on the surface of

textiles give the antibacterial properties to the surfaces so that these properties remain after repeated laundering. Through the immersion method continuous silver films with thicknesses varying from 40 to 600 nm were prepared. In case of using the spray method, silver nanoparticles were distributed non uniformly on the surface of fabric creating bactericidal patches on the surfaces. The later method can be more cost effective as less silver is required for this process. The developed methods can be used to coat conductive and nonconductive materials, also it can be used for porous substrates.

References

- [1] H. J. Klasen. Historical review of the use of silver in the treatment of burns. I. Early uses. *J Burns* 2000;26:117–130.
- [2] R.J. White. An historical overview of the use of silver in wound management. *Br J Nurs* 2001;10(15 Suppl.2):S3–S8.
- [3] A. Artemova. Silver heals and rejuvenates. Moscow – St. Petersburg "DILYA" 2002, 142.
- [4] Lansdown, A. B. Silver. 1. Its antibacterial properties and mechanism of action. *J Wound Care* 2002;11:125–130.
- [5] Thomas, S. and McCubbin, P. A comparison of the antimicrobial effects of four silver-containing dressings on three organisms. *J Wound Care* 2003;12:101–107.
- [6] Schindler, W.D.; Hauser, P.J. *Chemical Finishing of Textiles*; Woodhead Publishing Limited: Cambridge, UK, 2004.
- [7] Derek, H. *Textile Finishing*; Society of Dyers & Colourists: West Yorkshire, UK, 2003
- [8] Margaret Ip, Sau Lai Lui, Vincent K. M. Poon, Ivan Lung, Andrew Burd. Antimicrobial activities of silver dressings: an in vitro comparison. *Journal of medical microbiology* 2006;55:59-63

- [9] Darouiche, R. O. Anti-infective efficacy of silver-coated medical prostheses. *Clin Infect Dis* 1999;29:1371–1377.
- [10] Furno, F., Morley, K. S., Wong, B. & 7 other authors. Silver nanoparticles and polymeric medical devices: a new approach to prevention of infection? *J Antimicrob Chemother* 2004;54:1019–1024.
- [11] Heggers, J., Goodheart, R. E., Washington, J., McCoy, L., Carino, E., Dang, T., Edgar, P., Maness, C. & Chinkes, D. Therapeutic efficacy of three silver dressings in an infected animal model. *J Burn Care Rehabil* 2005;26:53–56.
- [12] Lansdown, Alan B.G. *Silver in Healthcare: Its Antimicrobial Efficacy and Safety in Use*. Royal Society of Chemistry 2010; p. 159. ISBN 1-84973-006-7.
- [13] Duquesne, Sophie et al. *Multifunctional barriers for flexible structure: textile, leather, and paper* 2007; p.26. ISBN 3-540-71917-2.
- [14] V.I. Belevantsev, I.V. Bondarchuk. Institute of Inorganic Chemistry of SD RSA. *Essay properties of silver and its compounds. Application of drugs of silver in medicine*. Novosibirsk 1994:89-95.
- [15] E.Sh. Savadyan. *Modern trends in the use of silver antiseptics*. *J Antibiotics and Chemotherapy* 1989; 11:874-8.
- [16] M.I. Shalkauskas, A.Yu. Vashkylis. *Chemical metallization of plastics*. L.: Chemistry 2000; 144.
- [17] A.G. Liakumovich, B.S. Friedman, A.B. Silberman, M.S. Gusev. *The current state of chemical-galvanic plating of plastics (review)*. *Plastics* 1989, 2:40-43
- [18] M. Hocking, W. Vasatasri, P. Sidky. *Metallic and ceramic coatings: production, properties and application*. M.-Mir 2000; 518.
- [19] RF patent № 2257423 from 27/07/2005, LLC "Obninsk Center for Powder Spray".

- [20] Materials of the 4th All-Russian conference "Technologies of repair, restoration, strengthening and renovation of machines, equipment and metal constructions", St. Petersburg, April 16-18, 2002:136-140.
- [21] Yu Xingwen, Cao Chunan etc. Study of double layer rare earth metal conversion coating on aluminum alloy LY12. *Corrosion Science* 2001;43:1283-1294.
- [22] O.I. Lomovsky, V.V. Boldyrev. Palladiumless metallization in technology of printed circuit boards. *Journal of Applied Chemistry* 1989; 62(II):2444-2455.
- [23] Lomovsky O.I., Zaikova Ĭ.O. Thermal Decomposition of Copper Hypophosphite and Possibility of the Reaction Control. *Thermochemica Acta*, 1986;92:645-648.
- [24] Ilana Perelshtein, Guy Applerot, Nina Perkas, Geoffrey Guibert, Serguei Mikhailov and Aharon Gedanken. Sonochemical coating of silver nanoparticles on textile fabrics (nylon, polyester and cotton) and their antibacterial activity. *Nanotechnology* 2008; 19(24):5705
- [25] S.A. Zyuzkevich. Cleaning of parts from grease before plating. *World of galvanics* 2007; 1:34.
- [26] Yu.G. Sindeev. *Galvanic coatings*. M.: Phoenix 2000; 251.
- [27] Yu.D. Hamburg. *Galvanic coatings. Reference manual*. M.: Technosphere 2006, 216 c.
- [28] Sh. T. Koshkarbaeva, S.Z. Nauryzova, M.S. Sataev and A.B. Tleuova. Low-temperature gas-phase metallization of dielectrics. *Oriental journal of chemistry* 2012, 28 (3):1281-1283.
- [29] Koshkarbaeva S.T., S.Z. Nauryzova, M.S. Sataev and A.B. Tleuova. *Oriental journal of chemistry* 2012, 28 (3):1281-1283
- [30] Yu.F. Shkarovsky, K.A. Lynchak, V.B. Chernogorenko, *Methods of phosphides analysis*. Book: Obtaining, properties and application of phosphids. – Kiev 1977; 76-78.

Table 1. Total elemental analysis of the spectra of the electronic images of textile with applied silver immersed in the solution CuSO_4 - 200 g/l.

Element	Weight, %		
	spectrum 1 (Fig. 4a)	spectrum 1 (Fig. 4b)	spectrum 2 (Fig. 4b)
C	29	27	43
O	40	22	34
P	1.2	1.8	0.7
Ag	30	48	19

Table 2. Elemental composition of the spectra of the electronic images of textile in which the introduction of silver was carried out by spraying a solution of CuSO_4 - 200 g/l.

Element	Weight, %		
	spectrum 1 (Fig. 6a)	spectrum 1 (Fig. 6a)	spectrum 2 (Fig. 6b)
C	27	59	32
O	22	38	27
P	1.8		1.4
Ag	48		33
S			0.5
Cu			1.6

Figure caption

Fig. 1. Scheme of the laboratory-scale plant for phosphine generation.

1 - reaction vessel, 2 - weighed amount of zinc phosphide, 3 - orifice, closed with a rubber ring, 4 - pet-cock for acid supply, 5 - burette for acid, 6 - vessel to collect phosphine

containing gas, 7 - intermediate vessel with water, 8 - phosphine containing gas receiver and 9 - level vessels.

Fig. 2. Scheme of laboratory-scale plant for applying copper-phosphorus films.

1 - sample, 2 - cover 3 - plating vessel, 4 - vessel with phosphine, 5,6 - level vessels; 7, 8 - faucets, 9 - a vessel with a solution of copper sulphate, 10 - a vessel with copper carbonate.

Fig. 3. Image of copper phosphide film obtained on a smooth nickel sample.

Fig. 4. SEM image of textile (a) and individual sections of textile (b) with applied silver immersed in the solution CuSO_4 - 200 g/l.

Fig. 5. Samples of fabric placed in an agar-agar growth medium. 1-fabric without silver coating, 2-fabric with silver coating; 3 - fabric with silver coating and it has been subjected to 10 washings.

Fig. 6. Sample of textile (a) and individual sections of textile (b) in which the introduction of silver was carried out by spraying a solution of CuSO_4 - 200 g/l.

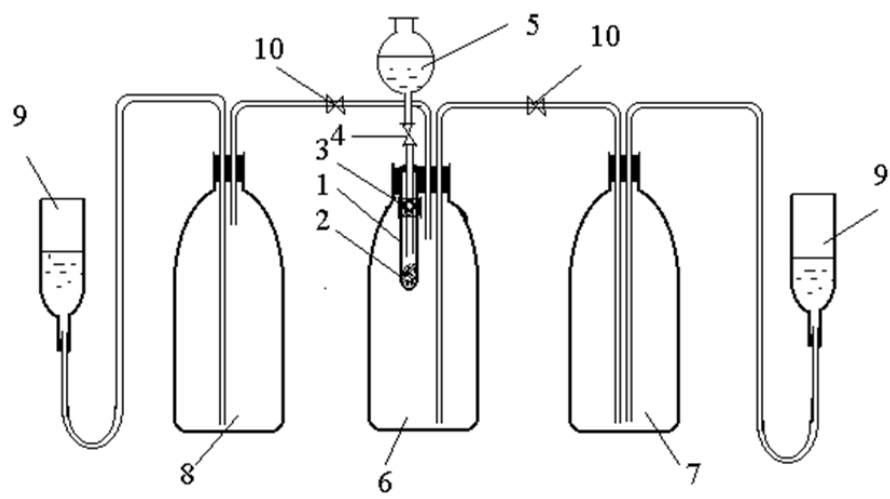

Figure 1

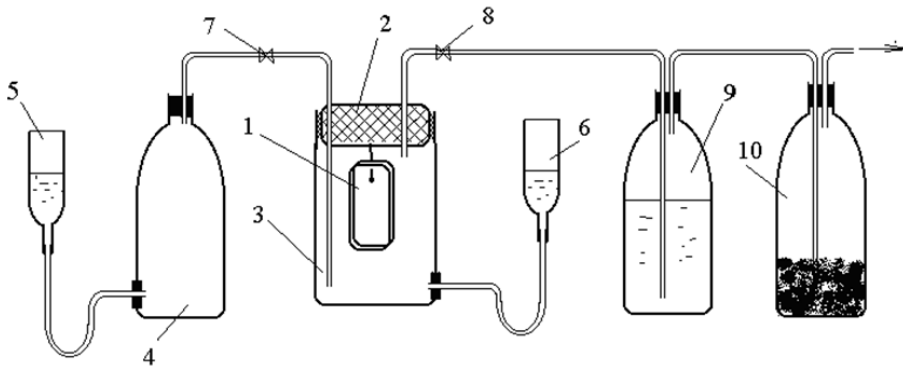

Figure 2

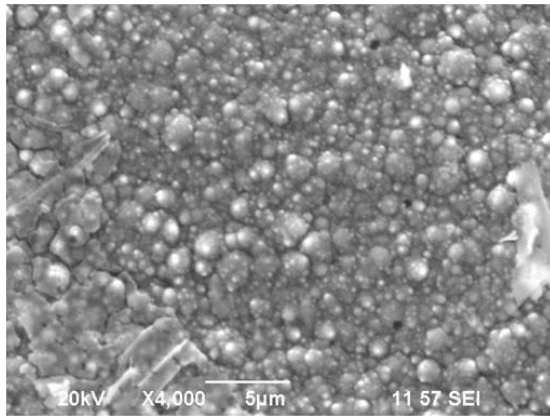

Figure 3

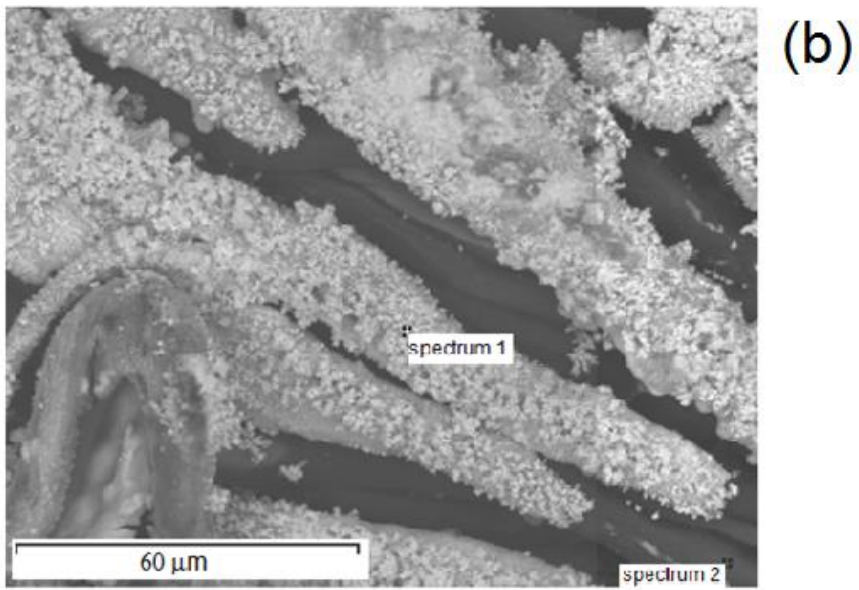
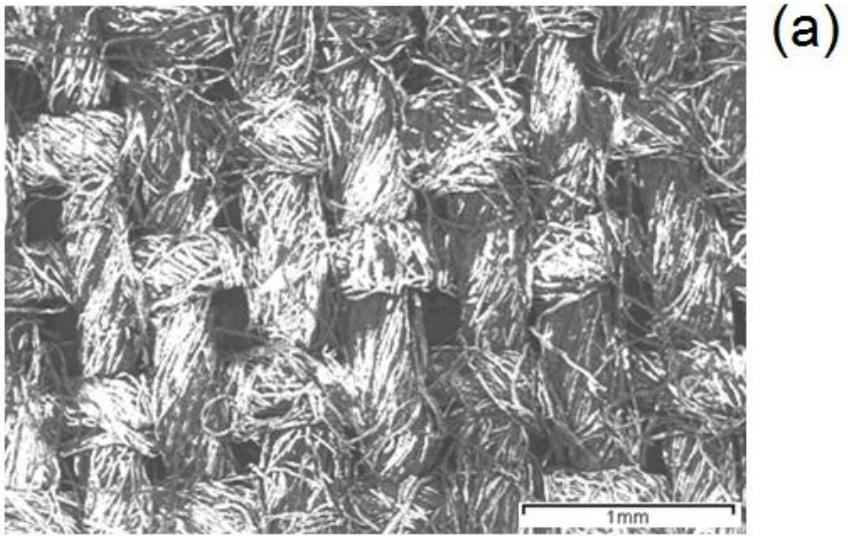

Figure 4

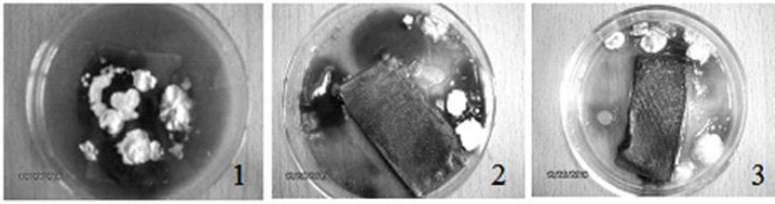

Figure 5

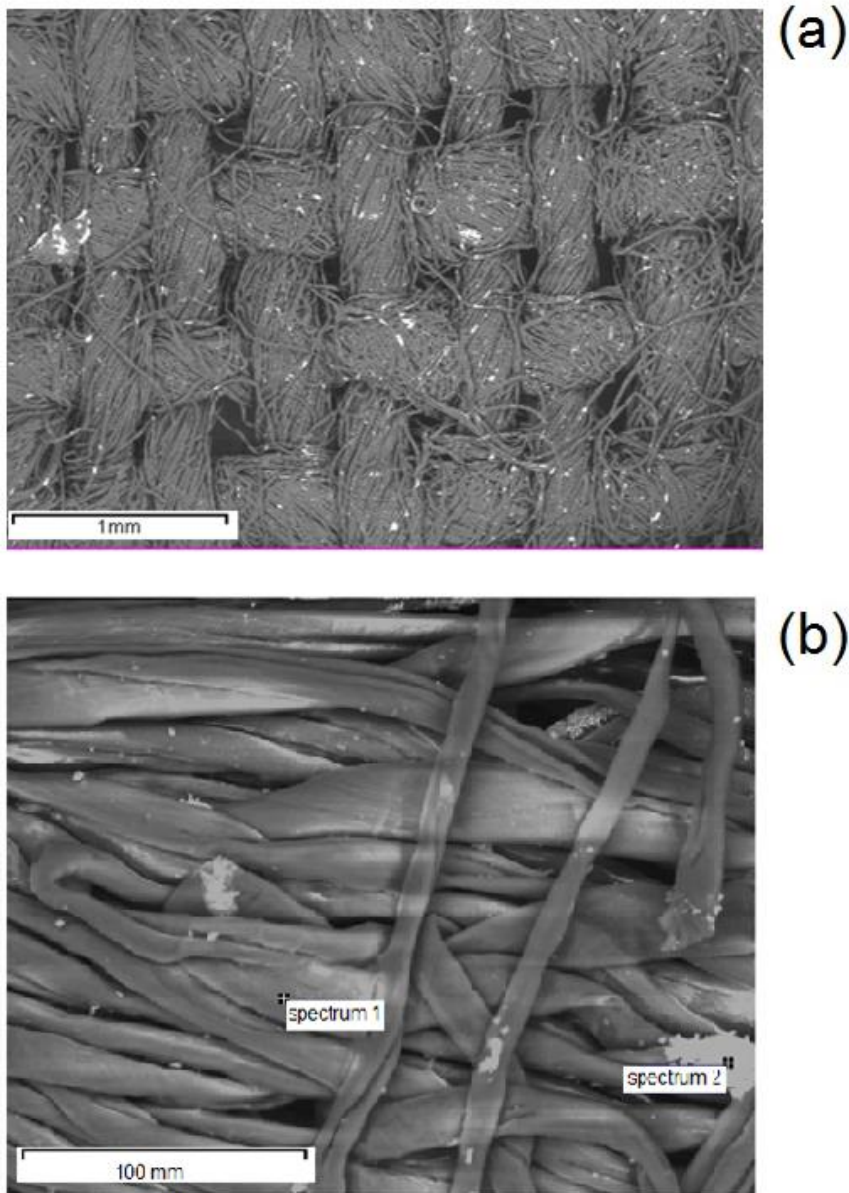

Figure 6

