

Numerical study assessing various ammonia/methane reaction models for use under gas turbine conditions

Abbreviations

CRN	Chemical Reactor Network
STP	Standard temperature and pressure
E.R.	Fuel–air equivalence ratio
T	Temperature of unburnt mixture

ABSTRACT

Ammonia as an alternative fuel and hydrogen carrier has received increased attention in recent years. To explore the potential of co-firing ammonia with methane for power generation, studies involving robust mathematical analyses is required to progress towards industrial implementation. To explore the chemical kinetic mechanisms best suited to ammonia/methane combustion in gas turbines, five different detailed mechanisms are compared to assess their efficacy in representing the reaction kinetics under practical gas turbine combustor operating conditions. Ignition delay time is compared with recently published predictions showing that the mechanisms of Tian and Teresa exhibit the best accuracy over a large range of conditions. A one-dimensional simulation was also conducted using a Chemical Reactor Network (CRN) model, thus providing a relatively quick estimation of the combustion mechanisms under swirling combustion conditions. The simulation of NO_x emissions indicate that the Tian mechanism performs better than the others considered. Hence, the Tian mechanism was selected as the most appropriate for further studies of ammonia/methane combustion through a set of experiments carried out at various equivalence ratios and pressure conditions. Finally, sensitivity and pathway analyses were also performed to identify important reactions and species under high-pressure conditions, areas that need more attention for model development and emission control in future studies.

Keywords: Ammonia/methane combustion, detailed kinetic mechanisms, gas turbine, Ignition delay , NO_x

1 Introduction

Ammonia is a promising energy storage material which could be utilised to replace conventional fossil fuel under the background of ever increasing energy demand and climate change issues. When derived

from renewable sources, ammonia can be a long-term sustainable fuel capable of fulfilling some of the energy demand in isolated areas disconnected from main national grids. Compared to other fuels such as hydrogen, biofuels, shale gas, dimethyl ether, etc. ammonia can also have many advantages for its storage, delivery and distribution. For instance, ammonia contains a large hydrogen component but it does not have the same issues during storage as it can be converted into a liquid at relatively low pressure (~8 bar). Moreover, as ammonia is an important chemical used as a fertilizer, there are already well established infrastructures and experience for its storage, handling, transportation and distribution worldwide.

Currently there are several groups trying to utilize ammonia for power systems, mostly in internal combustion engines [1-5]. However, power obtained from such units is relatively modest, typically in the 0.1 – 1 MW range. Thus similarly responsive but larger power generators will be required to meet the demands of electrical grids. As a result, considering the pressure to reduce carbon dioxide emission and finite resources of fossil fuels, using “green” ammonia in gas turbines for power generation is an interesting proposition. However, there is still a dearth of information relating to the utilization of ammonia in gas turbine combustors.

Although research has been undertaken for operational flame limits, chemical models, flame speed and internal combustion engines, gas turbines have played a minor role using this fuel. Academia has shown some development in the understanding of these systems, but this is limited [6-9]. Results show a series of challenges when utilising this fuel including: a) lower flame temperatures and slower kinetics; b) stability and efficiency problem; c) requirements for pre-vapourising the ammonia ; d) pre-cracking of the molecule to improve ignition reliability and increase burning rate. NASA also identified during their XLR-99 program the need for “combustor enhancers” such as hydrogen, gasoline, kerosene, propane, etc., especially during start-up and idle [9]. Another potential fuel enhancer is methane, as this is the main fuel of gas turbines for power generation. An ammonia/methane blend could be used not only from green ammonia sources, but also from by-product ammonia obtained from industrial processes. Ammonia addition could support peak-hour energy consumption requirements with fuel cost reduction. For instance, an immediate beneficiary of this blend could be steelworks companies that produce ammonia as a by-product of coke oven gas cleaning [10, 11]. Therefore, this research appraises

ammonia/methane as the fuel to be studied for the purpose of application in gas turbine combustion for large scale power generation in these energy intensive industries.

To utilize ammonia/methane effectively in a gas turbine, it is essential to understand better the reaction mechanism using detailed chemical kinetic models. In addition, computational fluid dynamics (CFD) simulations can serve as a powerful tool for analysing and designing ammonia combustion systems. Developing a CFD-based methodology alongside a detailed ammonia mechanism can help to capture more accurate information for the prediction of NO_x emissions, turbulent reacting flows, combustion dynamics, ignition delays, etc. Previous studies [12-15] have concentrated on developing detailed chemical mechanisms of ammonia combustion. However, the challenging conditions in gas turbine combustors such as high inlet temperature, high pressure, recirculation flow fields require a more specific study on the chemical progression of ammonia/methane species, which is still immature in the development of large scale industrial systems.

Thus, there is a need to compare the performance of different detailed ammonia combustion mechanisms in order to define the most suitable at present, simultaneously identifying its weaknesses for further research. This can be resolved using numerical models to distinguish which one is capable of providing a better correlation to ammonia combustion kinetics under conditions of a typical gas turbine combustor. Without any previous study on the field, it is clear that there is a great opportunity in the area to develop new mechanisms, CFD simulations, experimental setups and industrial designs. The aim of this study is mainly to compare the performance of different detailed ammonia (NH₃) combustion mechanisms and distinguish which is most capable of representing ammonia/methane combustion kinetics under conditions of a typical gas turbine combustor. As a convenient way of evaluating the accuracy of detailed kinetic mechanisms, the ignition delay time of ammonia diluted with argon was calculated firstly for a wide range of temperatures and pressures. NO_x emissions were also predicted for validation against experiment data obtained through experiments using a gas turbine swirl burner. A 1D simulation was conducted for NO_x emissions calculation using a Chemical Reactor Network (CRN) model. Thus, influence of the boundary conditions towards NO_x formation were also analysed using the most suitable mechanism.

1.1 Reaction Mechanisms for Ammonia Combustion

A considerable number of studies on detailed mechanisms for ammonia oxidation have been conducted previously. Tian et al. [16] developed a 703 steps mechanism for CH_4/NH_3 premixed combustion at low pressure. The influence of NH_3/CH_4 mole ratio on flame structure was identified by using molecular-beam mass spectrometry (MBMS) and tunable synchrotron VUV photoionization. The model was validated recently against the experimental data of laminar burning velocity at various pressures [17]. Teresa et al. [18] studied the oxidation of NH_3 during oxy-fuel combustion of methane. A detailed chemical kinetic model is developed based on experimental data covering equivalence ratios ranging from fuel-rich to fuel-lean conditions at temperature ranges of 973–1773 K, involving 97 species and 779 reactions.

Another mechanism - which has over 85 species and 1200 reactions - was developed for small hydrocarbons flames by Konnov [19]. This mechanism provides full implementation of kinetic data for NO formation. This mechanism has been validated by many combustion studies including flame speed [13] and NO formation [20]. The Åbo Akademi (ÅA) scheme [21] is a gas-phase detailed chemical kinetic model that involves 60 species in 371 elementary gas-phase reactions. This mechanism was created for the simulation of biomass derivative gases combustion at moderate temperature. Since it takes into account the oxidation of light hydrocarbons, ammonia as well as the interactions between hydrocarbon and nitrogen-containing species, this mechanism is suitable for this study. The mechanism has been validated against various studies on flame speed, NO_x concentration, etc. over a wide range of temperatures and equivalence ratio [22]. The Gas Research Institution released its most updated version of the GRI 3.0 mechanism for methane combustion in 2005 [23], which contains 53 species and 325 chemical reactions. This mechanism has already been validated for ammonia-doped methane combustion [22]. GRI 3.0 has also been widely used for predicting nitrogen-oxide pollutants since it includes detailed kinetic mechanisms for NO_x formation through CH_4 combustion [24, 25].

In addition, there are a large number of studies concerning mechanisms for ammonia combustion. Skreiberg [26] established a detailed mechanism for ammonia oxidation in flames under fuel-rich conditions and moderate temperatures. Since ammonia chemical reactions are studied in the presence

of CH₄, H₂ and CO, it is recommended for modelling NO_x emissions of biomass combustion. Olivier [14] studied ammonia combustion kinetic mechanisms under high temperatures (1560–2455 K) and high pressure conditions for comparison with ignition delay time data. Glarborg et al [24] created a detailed chemical kinetic model in which interactions between hydrocarbons and nitrogenous species are well established. A modified model of the Dagaut mechanism has also been proposed in which significant improvements are achieved in modelling NO_x/N₂O data [14]. Li et al [27] studied methane and air flames doped with ammonia to analyse the formation of NO_x from fuel-N. This study also validated the capability of Konnov and Skreiberg mechanisms in predicting ammonia conversion. Kumar et al [13] studied ammonia/hydrogen combustion and laminar flame speed by comparing the performance of GRI-Mech3.0, Tian and Konnov detailed mechanisms. The study shows Tian and Konnov mechanisms are perform best in predicting combustion effects over a wide range of equivalence ratio (0.5-1.1) and NH₃/H₂ ratios (0-80% by energy). Nozari et al [12] proposed two reduced mechanisms for ammonia combustion based on Konnov mechanism, both of which demonstrated good performance in predicting flame speed and NO_x emission formation. Duynslaegher et al [28] also studied the kinetics of ammonia containing premixed flames for applications in spark ignition engines. Konnov, Tian, Lindstedt and Smith mechanisms are compared by mole fraction showing that only the first two performed best compared with experimental data.

Although there are many detailed chemical mechanisms in the literature, only those which have been validated are considered for the numerical work in this study. In addition, considering that methane is the only combustion promoter for the ammonia based fuel in this study, five mechanisms are selected for the analysis. These are Tian, Teresa, Konnov, ÅA and GRI 3.0 mechanisms. Although they are not developed for conditions inside gas turbine combustors, it is meaningful to validate and expand their application range and compare the accuracy of these mechanisms for the application in gas turbine running on ammonia/methane blends.

2 Methodology

2.1 Experimental Setup

Experimental work was carried out using premix combustion of CH₄/NH₃ and air in a generic swirl burner representative of industrial systems, Fig. 1. This system is located at the Gas Turbine Research Centre (GTRC), Cardiff University. As shown in Table 1, experimental conditions vary from different pressures, equivalence ratios, ammonia/methane fuel concentrations and power outputs using a geometric swirl number of 1.05. Reynolds number varied from 10,800 to 21,000 for a range of operating conditions. In the experiments, the tested blend was successfully characterised only for 61% NH₃ –39% CH₄ (molar fraction) [29]. Moreover, the current setup allowed for ammonia mass flowrates up to 0.8 g/s. Herein 30 kW and 44 kW power loads were studied under these conditions, Table 1. During the experiments, the entire rig is confined by a quartz tube fitted to the system to provide a confinement for the flame, as utilised in modern gas turbine combustors. Coriolis mass flow meters were used to achieve measurements with $\pm 2\%$ deviation. An Avigilon 5 Mp H.264 HD camera was used to capture the flame during various stability stages and provide qualitative insights of the flame behaviour. A heated vacuum chemiluminescence analyser (Signal 4000VM) was employed to quantify NO_x concentrations with $\sim 5\%$ measurement error. Emissions data from the experiments were used to validate the numerical work in this study. Further details of these tests and the rig can be found in [29].

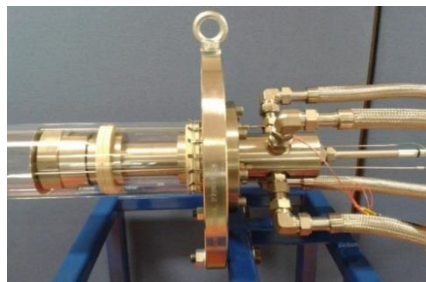

Fig. 1. Gas Turbine Combustor at the GTRC.

Table 1 Experimental conditions of ammonia/methane combustion

Mass NH ₃ [g/s]	Mass CH ₄ [g/s]	Mass O ₂ [g/s]	Mass Air [g/s]	Base Power [KW]	E.R.
1.0 atm					
0.80	0.47	3.68	16.66	43.85	0.81
0.82	0.47	2.93	13.25	44.30	1.02
0.82	0.47	2.62	11.88	44.30	1.14

0.82	0.47	2.40	10.86	44.30	1.24
0.80	0.47	2.18	9.85	43.85	1.37
2.0 atm					
0.58	0.34	2.73	12.35	31.75	0.80
0.58	0.34	2.10	9.57	31.75	1.03
0.58	0.34	1.91	8.65	31.75	1.14
0.58	0.34	1.77	8.00	31.75	1.23
0.58	0.34	1.54	6.98	31.75	1.42

2.2 Numerical Simulation

2.2.1. Ignition Delay Times Modelling

Ignition delay time is the time interval needed for a certain mixture to be ignited without external energy supply. Ignition delay is mainly affected by a mixture's composition, temperature and pressure. Numerical prediction of ignition delay times is helpful in understanding autoignition parameters, detailed kinetics and reduction of detailed mechanisms. In fact, as an important well-known validation technology, computational prediction of ignition delay times is usually compared with shock-tube experiments [30-32]. In this study, ignition delay times were modelled with a closed homogeneous reactor in CHEMKIN-PRO. In this model, the ignition delay time can be defined based on different criteria such as the time at which a certain species reaches the maximum concentration or the time at which an inflection point appears in pressure or temperature profiles [14, 30, 32].

In this study, ignition delay times are extracted as the time corresponding to the steepest rate of the OH generation [14]. The model is calculated at constant volume and adiabatic conditions. In the simulation, the ammonia and oxidiser mixtures are highly diluted (98-99%) to minimize effects of viscous, heat transfer and non-equilibrium as performed in shock-tube experimental conditions [33]. The numerical work was carried out under a wide range of pressures, temperatures and equivalence ratios to simulate the experimental results provided by Mathieu et al [14]. The five mechanisms mentioned above were tested to validate their accuracy in predicting the ignition delay times.

2.2.2 Chemical Reactor Network

A 1D simulation was conducted using a Chemical Reactor Network (CRN) model, which has proved to be effective for gas turbine simulations [34, 35]. In this study the CRN model is utilized to simulate ammonia/methane combustion in the swirl combustor used in the experimental campaign. Different

chemical reactors were employed to represent different areas in the combustor chamber. A Perfect Stirred Reactor (PSR) was used to simulate the premixing, recycling and flame zones, whilst a Plug Flow Reactor (PFR) was utilized to simulate the post-flame zone. The simulation of this work was conducted in a CHEMIKIN-PRO platform.

In the primary combustion zone, because due to strong recirculation, the reactants and temperature are generally homogeneously distributed. Therefore, the PSR model is most suitable for these conditions. The combustion model under steady state conditions in each zone is represented with its corresponding chemical reactor; PSR1 represents the mixing zone near the exit of the inlet; PSR2 represents the central recirculation zone, which was set at 20% recirculation; PSR3 represents the primary flame zone; PFR represents the post-flame zone, Fig. 2.

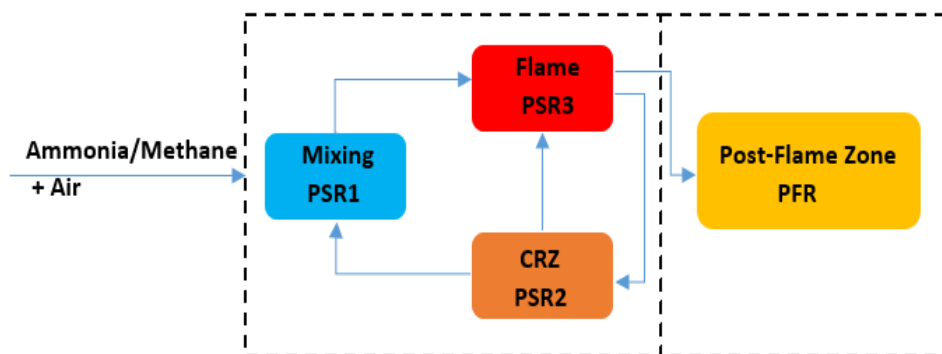

Fig. 2. Gas Turbine Network

In order to validate the simulation results, numerical work was performed at Standard Temperature and Pressure (STP; 1 atmosphere, 293 K) conditions and 2 atmospheres conditions to correlate with the experimental results performed in the generic swirl burner, Table 1. Different equivalence ratios were studied at both pressures. Calculations were performed with the five mechanisms: Tian, Teresa, Konnov, ÅA and GRI 3.0 mechanisms.

Further simulations were carried out using the chemical mechanisms that showed the best agreement with Mathius et al [14] experiments and those obtained in the experimental campaign with the generic swirl burner [29]. These simulations were performed under a variety of inlet temperatures and pressure conditions. Thus, the influence of these parameters on the combustion characteristics of ammonia/methane were studied under elevated ambient conditions of relevance to gas turbines.

3 Results and Discussion

3.1 Validation of Ignition Delay Times

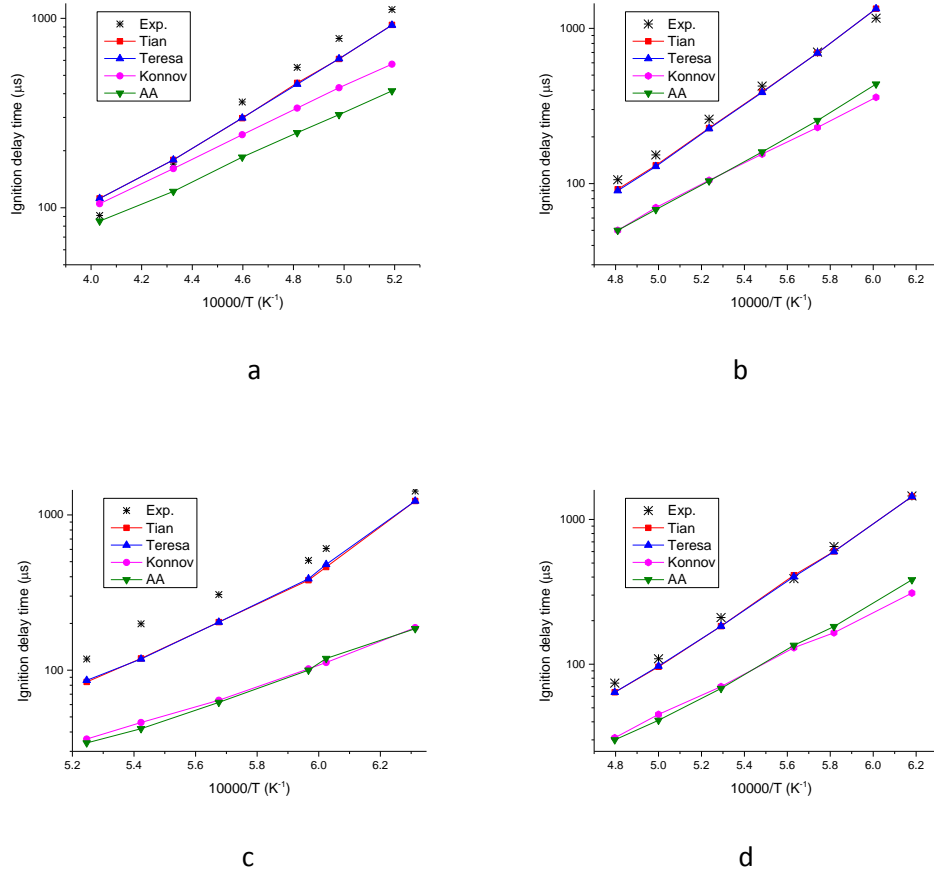

Fig. 3. Performance of different mechanisms with respect to ignition delay times of NH₃ mixtures. a) 1.4 atm, E.R. = 0.5, 99% Ar; b) 11.0 atm, E.R. = 1.0, 99% Ar; c) 30.0 atm, E.R. = 2.0, 99% Ar; d) 11.0 atm, E.R. = 1.0, 98% Ar. Experiments as in [14].

Fig. 3. presents a validation study for ignition delay times using different chemical kinetic mechanisms. Ignition delay times of ammonia-oxygen-argon mixtures are calculated at equivalence ratios of 0.5, 1.0 and 2.0 under pressures of 1.4, 11.0 and 30.0 atm. Also, 98% and 99% dilution in Ar were studied. During the calculation with different mechanisms, no ignition occurred using GRI 3.0 mechanism. Therefore, this was discarded and only the simulation results of the other four mechanisms are presented.

Most of the mechanisms have predicted smaller ignition delay times compared to experimental data. The exceptions are the Tian and Teresa mechanisms which have shown the best agreement with data across all conditions. This was expected, as Teresa mechanism follows many constant reaction rates

adopted in Tian mechanism. The ÅA mechanism shows the worst performance whilst Konnov mechanism lies between Tian and ÅA for the prediction of these conditions, Fig. 3a. The Konnov and ÅA mechanisms provide similar predictions at high pressure, though they are still far away from the experimental results.

Although the mechanisms of Tian and Teresa are slightly too reactive, the accuracy is acceptable considering experimental uncertainty is estimated to be in the order of 10% [14]. Another possible cause for the small discrepancies can be either that the isothermal boundary condition are not exactly the same or the homogeneity accuracy in the numerical calculation.

Therefore, the Tian mechanism was selected to predict ignition delay times of ammonia/methane mixtures diluted in 99%Ar. Fig. 4. shows the ignition delay times of an ammonia/methane mixture under different equivalence ratios and pressures. The mole fraction of ammonia and methane was set at 61% and 39%, respectively. This is the same ratio as that utilised in the generic swirl burner experimental campaign, Table 1.

As observed in Fig. 4., pressure has a significant effect on the ignition delay times for ammonia/methane combustion bends while the equivalence ratio effect is much smaller. The ignition delay time decreases with the increase of pressure and increases with the increase of equivalence ratio. For a specific equivalence ratio, the factor (τ_{1atm}/τ_{11atm}) between ignition delay times obtained at 1.0 atm and 11.0 atm is greater than ($\tau_{11atm}/\tau_{30atm}$) at 11.0 and 30.0 atm, i.e. for an equivalence ratio = 1.00, the factor between 1.0 and 11.0 atm is around 6, whilst between 11.0 atm and 30.0 atm the factor is only 1.8. Compared to the ammonia/oxygen/argon mixture, the ignition delay time of the ammonia/methane/oxygen/argon mixture is relatively lower, since methane has much lower resistance to auto-ignition than pure ammonia.

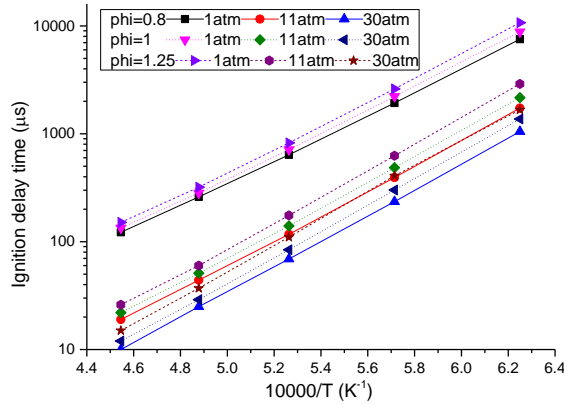

Fig. 4. Ignition delay time of ammonia/methane mixture

3.2 Appraisal of NO_x Emission Predictions

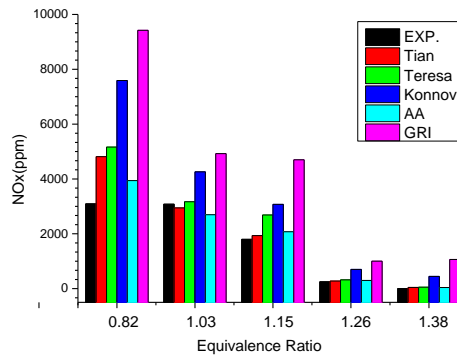

Fig. 5. NO_x emission under STP condition. Experiments as in [29].

At atmospheric pressure, all the mechanisms overpredict the NO_x emissions significantly under lean conditions, Fig. 5. The AA mechanism shows a better performance than others at these conditions and the same can be said for the 2.0 atm pressure case. Obviously, equivalence ratio has a significant effect on the NO_x formation kinetics. The relatively big deviation from experimental data is mainly due to the development of these mechanisms that were specifically performed for lean combustion conditions. For instance, Tian's mechanism was developed under stoichiometric conditions. In Teresa's and Konnov's mechanism both mechanisms show good performance under fuel rich conditions rather than lean ones [18, 19]. Since AA mechanism has been validated under a wide range of conditions, it performs better than others at fuel lean conditions. Although traditionally lean combustion is used to reduce flame temperature which leads to less thermal NO_x formation in gas turbines, ammonia based fuel mixtures

seem to generate greater NO_x under these lean conditions, Fig. 5 and Fig. 6. Thus, stoichiometry should be swapped to fuel rich conditions to reduce the total NO_x emissions for gas turbine applications.

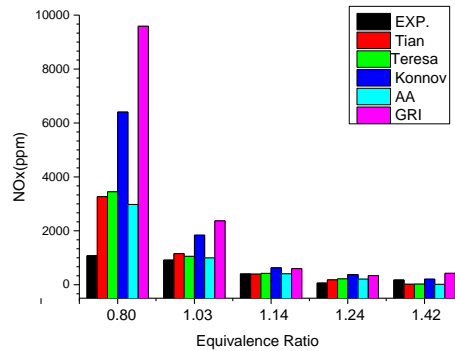

Fig. 6. NO_x emission concentration under 2.0 atm. Experimental Data from [29].

Under fuel rich conditions all five mechanisms predicted good trends of NO_x formation as observed in Fig. 5. Increasing the equivalence ratio of the mixture decreases NO_x rapidly. Overall, most of the mechanisms overestimate NO_x emissions for the equivalence ratios studied, while only Tian and ÅÅ mechanisms underestimate NO_x formation at conditions closest to stoichiometric, i.e. equivalence ratio=1.03. In the fuel rich zone near stoichiometric condition, the Tian mechanism shows the best performance.

Generally all mechanisms have provided a good prediction for NO_x trends within the range of fuel rich conditions at higher pressure, Fig. 6. In most conditions all mechanisms overestimated NO_x emissions, with the Tian and ÅÅ mechanisms performing better than the other mechanisms. At an equivalence ratio of 1.14, the best prediction is performed by ÅÅ and Tian mechanisms for which the calculated values are 404 ppm and 395 ppm, respectively, compared to 405 obtained experimentally. A significant reduction of NO_x emission can be observed, compare with Fig. 5. This is mainly due to pressure effects on the kinetics of ammonia/methane combustion as fuel NO_x will be reduced as a consequence of a thinner reaction zone while thermal NO_x will increase due to a more intense combustion. However, a better understanding of fuel NO_x kinetic reaction pathways need to be analysed under gas turbine conditions to corroborate the previous assertion.

Based on all previous calculations, Tian mechanism has provided satisfactory predictions of NO_x in most cases, so this scheme has been selected for further studies of CH_4/NH_3 combustion under gas turbine conditions.

3.3 Gas turbine simulations

Overall the Chemical Reactor Network simulation can give useful information on the trends of NO_x formation under real gas turbine conditions. It is appreciated that the simulations do not reveal further details of flame stability, turbulence and heat transfer features as in real combustors. Moreover, lean operating conditions over-predict the formation of NO_x . Thus, further research is needed to take into account these effects for real combustors.

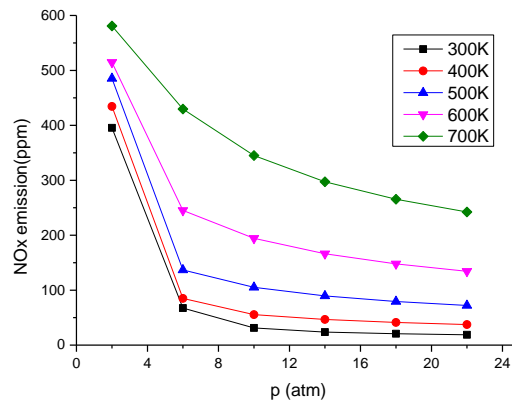

Fig. 7. NO_x emission at various inlet temperatures and pressure conditions

Results show the influence of inlet temperature (300-700 K) and pressure (1.0-22.0 atm) on NO_x formation, Fig. 7. Simulations were performed using Tian mechanism integrated with the CRN model. The equivalence ratio used was set at 1.14. NO_x emissions decrease with the increase of pressure with considerable decreases observed from medium pressure to high pressure. This indicates that the usage of ammonia/methane blends in gas turbines will be improved as NO_x emissions will be likely reduced under real operation conditions. On the other hand, NO_x emissions increase with augmented inlet temperatures. Although emissions increase threefold at representative industrial conditions, i.e. at 700K NO_x emissions have gone up to ~270 ppm, these emissions can still be recovered using conventional scrubbing techniques, thus showing potential for co-firing ammonia and methane blends at high pressure.

Increase in NO_x is mainly due to augmentation of thermal NO_x . As inlet temperature increases, reactivity of the blend is increased thus enhancing nitrogen oxides formation. On the other hand, increase in pressure will compact the flame reaction zone and limit localized points of high temperature where thermal NO_x are formed. Thus, thermal NO_x will augment as a consequence of pressure via intensity increase of the reaction zone, while fuel NO_x will show a reduction that will have a greater impact on the total amount of emissions, Fig. 7.

3.4 Sensitivity Analysis

An OH sensitivity analysis of the Tian mechanism was conducted to identify the important reactions for ammonia/methane combustion at high pressure, Fig. 8. The ÅA mechanism was also analysed for comparison purposes, Fig. 9. The condition selected for the analysis is an equivalence ratio of 1, pressure of 17 atm and temperature of 2000K. The composition of the $\text{NH}_3/\text{CH}_4/\text{O}_2/\text{Ar}$ mixture is the same as in Fig. 4.

The reactions $\text{CH}_3+\text{O}_2\rightleftharpoons\text{CH}_2\text{O}+\text{OH}$ and $\text{NH}_3+\text{OH}\rightleftharpoons\text{NH}_2+\text{H}_2\text{O}$ have the largest impacts on the production of OH radicals in both mechanisms. The difference between mechanisms is that these reactions play a more prominent role in Tian mechanism than in ÅA mechanism. Even further, in Tian's and ÅA mechanisms the reaction $\text{CH}_3+\text{HO}_2\rightleftharpoons\text{CH}_4+\text{O}_2$ is the second most promoting reaction of OH while in ÅA mechanism the reactions $\text{O}+\text{OH}\rightleftharpoons\text{H}+\text{O}_2$ and $\text{CH}_3+\text{H}(+\text{M})\rightleftharpoons\text{CH}_4(+\text{M})$ also significantly enhances the OH production. In fact, differences between rate constants of some key reactions produce also a great impact on OH formation. For instance, concerning the reaction $\text{CH}_3+\text{H}(+\text{M})\rightleftharpoons\text{CH}_4(+\text{M})$, the rate constant is $k=2.1\times 10^{14}$ in Tian's mechanism while in ÅA the value is $k=6\times 10^{16}\cdot\text{T}^{-1}$. This simple case shows how these differences can considerably alter the performance when predicting the ignition delay time.

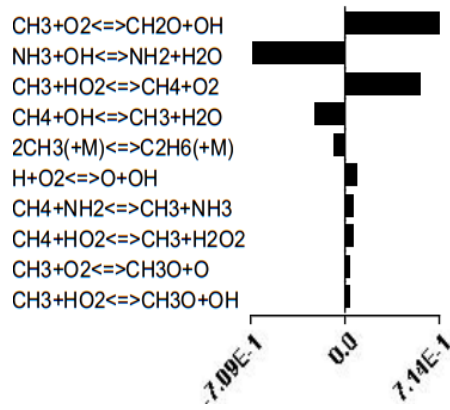

Fig. 8. OH sensitivity using Tian mechanism.

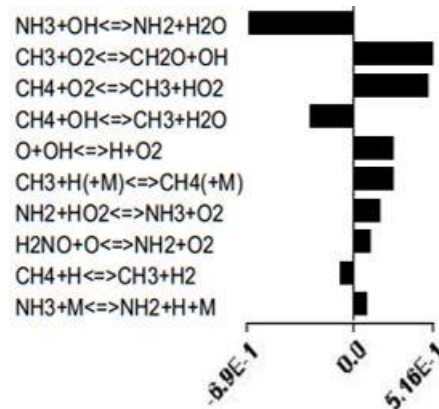

Fig. 9. OH sensitivity using ÅA mechanism.

Fig. 10. shows the sensitivity analysis results of NO species to identify the important reactions in an ammonia/methane flame zone. $\text{NH}+\text{OH} \rightleftharpoons \text{HNO}+\text{H}$ reaction is the most promoting reaction for NO formation while reactions $\text{NH}_2+\text{NO} \rightleftharpoons \text{NNH}+\text{OH}$ and $\text{N}+\text{NO} \rightleftharpoons \text{N}_2+\text{O}$ play important roles for the NO consumption. The importance of these reactions is quite different from the results observed in [16] at low pressure. This indicates that the high pressure conditions experienced in gas turbines considerably affect the reaction kinetics compared to low pressure conditions. To illustrate the differences between the selected mechanisms and taking the inhibiting reaction $\text{N}+\text{NO} \rightleftharpoons \text{N}_2+\text{O}$ as an example, rate constants are 2×10^{13} for Tian's and Teresa's mechanisms, $3.3 \times 10^{12} \cdot T^{0.3}$ in ÅA and $2.7 \times 10^{13} \exp(1500/RT)$ in GRI 3.0, while there is no such elementary reaction in Konnov's mechanism. These variances explain why NO predictions are closer between Tian's and Teresa's mechanisms while the deviation is greater with GRI 3.0 and Konnov's, Fig. 6. Similarly, most constants show a great variety of values between mechanisms. Therefore, the different rate constants for some sensitive reactions can illustrate the differences in the treatment of the NO formation between the mentioned mechanisms, thus being

responsible for the different NO emission predictions for the swirl burner presented in this study. Moreover, the sensitivity analysis also indicates that the reactions between hydrocarbon and nitrogen species have very little effect on the NO formation.

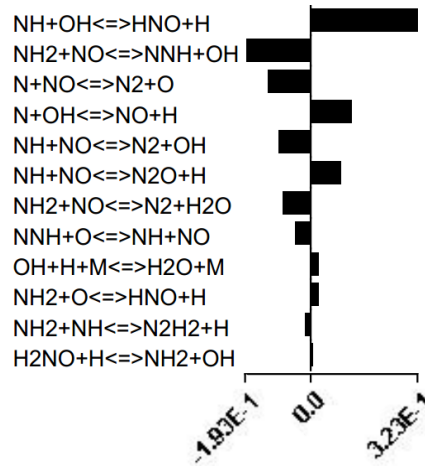

Fig. 10. NO sensitivity of Tian mechanism. E.R. 1.14, 17 atm and 300K inlet temperature.

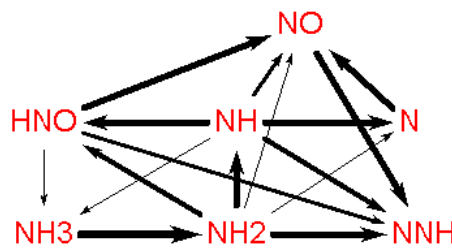

Fig. 11. Pathway analysis of the NO formation in the flame zone at high pressure. E.R. 1.14, 17 atm and 300K inlet temperature.

Fig. 11. shows the main reaction pathways of NO formation. The major source of the NO formation comes from oxidation of HNO and N. When ammonia is consumed initially with O/OH, NH₂ is produced. Then the NH₂ is mainly converted into HNO and NH. As the sensitivity analysis shows, the reaction $\text{NH} + \text{OH} \rightleftharpoons \text{HNO} + \text{H}$ plays the key role in the NO formation process. The conversion from HNO to NO is mainly through the reaction $\text{HNO} + \text{M} \rightleftharpoons \text{NO} + \text{H} + \text{M}$ with a 45.4% contribution, while $\text{HNO} + \text{H} \rightleftharpoons \text{NO} + \text{H}_2$ and $\text{HNO} + \text{OH} \rightleftharpoons \text{NO} + \text{H}_2$ are also active but with smaller net contribution to NO formation.

On the other hand, because of the high temperature in gas turbine flames, hydrogen atoms are quite easily stripped off NH to produce N [26]. Then the formation of NO created via oxidation of nitrogen radicals (N) is mainly via the reaction $\text{N} + \text{OH} \rightleftharpoons \text{NO} + \text{H}$. Similar analysis can be conducted for the NO degradation pathway so that a deep insight can be gained into the factors needed to reduce NO_x

emissions under gas turbine conditions. NO is mainly consumed by NH_2 by the reactions $\text{NH}_2 + \text{NO} \rightleftharpoons \text{N}_2 + \text{H}_2\text{O}$ and $\text{NH}_2 + \text{NO} \rightleftharpoons \text{NNH} + \text{OH}$ forming N_2 or NNH . NNH is finally converted into N_2 through the reaction $\text{NNH} \rightleftharpoons \text{N}_2 + \text{H}$. Therefore, the fate of the NH_i species to a large extent determines the selectivity of the fuel towards the formation of NO or N_2 in the flame.

4 Conclusion

A comprehensive comparison of different detailed mechanisms was performed to study the co-firing of ammonia/methane blends in gas turbines as a possible choice to reduce carbon emissions. Several recently published mechanisms including Tian, Teresa, Konnov, ÅA and GRI 3.0 mechanisms were employed to determine their performance for the prediction of ignition delay times and NO_x emission using ammonia blends.

Ignition delay time calculations for highly diluted ammonia showed that Tian's and Teresa's mechanisms yielded the best performance. Thus, Tians' mechanism was used for ignition delay time predictions utilising ammonia/methane blends. The results showed that high pressure conditions reduced ignition delay times for these blends significantly whilst equivalence ratio has a relatively small effect.

NO_x emission calculations were conducted with a Chemical Reactor Network to simulate a real swirl burner of gas turbine. The results indicate that slightly fuel rich combustion can have an advantage to lower NO_x emission in gas turbines. Hence, Tian's mechanism is recommended as the best suited for ammonia/methane combustion studies in gas turbine at fuel-rich conditions.

Tian's mechanism was used on further analyses to determine the effect of pressure and temperature on NO_x production. Results showed that high pressure can achieve a considerable decrease of NO_x emission whilst high inlet temperatures to the combustor will promote them. Sensitivity and reaction were carried out to identify important reactions in ammonia/methane combustion. Results showed that $\text{CH}_3 + \text{O}_2 \rightleftharpoons \text{CH}_2\text{O} + \text{OH}$ plays the most important role in ignition chemistry while $\text{NH} + \text{OH} \rightleftharpoons \text{HNO} + \text{H}$ has the largest impact on the NO conversion at high pressure. The major source of the NO formation comes from oxidation of HNO and N under gas turbine combustion conditions.

Additional studies are still needed for a deeper insight into the ammonia chemistry so that the mechanism can be refined to be better suited for ammonia/methane combustion under gas turbine conditions.

Acknowledgements

Mr. Xiao would like to thank all the support given by the Chinese Scholarship Council (CSC) in order to complete his PhD studies at the UK.

References

- [1] S.M. Grannell, D.N. Assanis, S.V. Bohac, D.E. Gillespie, The Fuel Mix Limits and Efficiency of a Stoichiometric, Ammonia, and Gasoline Dual Fueled Spark Ignition Engine, *Journal of Engineering for Gas Turbines and Power*, 130 (2008) 042802.
- [2] C.S. Shawn Grannell, Don Gillespie, A Comparison of Combustion Promoters for Ammonia and Two Ways to Run Engines on Ammonia as the Only Fuel, in: 2010 Annual NH₃ Fuel Conference, 2010
- [3] S. Frigo, R. Gentili, Analysis of the behaviour of a 4-stroke Si engine fuelled with ammonia and hydrogen, *International Journal of Hydrogen Energy*, 38 (2013) 1607-1615.
- [4] F.R. Westlye, A. Ivarsson, J. Schramm, Experimental investigation of nitrogen based emissions from an ammonia fueled SI-engine, *Fuel*, 111 (2013) 239-247.
- [5] A.J. Reiter, S.-C. Kong, Combustion and emissions characteristics of compression-ignition engine using dual ammonia-diesel fuel, *Fuel*, 90 (2011) 87-97.
- [6] W.E. Lear, Ammonia-Fueled Combustion Turbines, in: 2007 Annual NH₃ Fuel Conference, NH₃ Fuel Association, 2007.
- [7] E.B. Karabeyoglu A, Fuel Conditioning System for Ammonia Fired Power Plants, in: 2012 Annual NH₃ Fuel Conference, NH₃ Fuel Association., 2012.
- [8] K.P. Meyer T, Li M, Redfern K, Diaz D Ammonia Combustion with Near-Zero Pollutant Emissions, in: 2011 Annual NH₃ Fuel Conference, NH₃ Fuel Association, 2011.
- [9] B.M.S. Ganley J, Engine-Ready, Carbon Free Ammonia Fuel., in: 2010 Annual NH₃ Fuel Conference, NH₃ Fuel Association, 2010.
- [10] U.N. UNIDO, Fertilizer Manual, Kluwer Academic Publishers, The Netherlands, 1998.
- [11] P. M, The Coke Oven By-Product Plant in, 2008.
- [12] H. Nozari, A. Karabeyoğlu, Numerical study of combustion characteristics of ammonia as a renewable fuel and establishment of reduced reaction mechanisms, *Fuel*, 159 (2015) 223-233.
- [13] P. Kumar, T.R. Meyer, Experimental and modeling study of chemical-kinetics mechanisms for H₂-NH₃-air mixtures in laminar premixed jet flames, *Fuel*, 108 (2013) 166-176.
- [14] O. Mathieu, E.L. Petersen, Experimental and modeling study on the high-temperature oxidation of Ammonia and related NO_x chemistry, *Combustion and Flame*, 162 (2015) 554-570.
- [15] C. Duynslaegher, F. Contino, J. Vandooren, H. Jeanmart, Modeling of ammonia combustion at low pressure, *Combustion and Flame*, 159 (2012) 2799-2805.
- [16] Z. Tian, Y. Li, L. Zhang, P. Glarborg, F. Qi, An experimental and kinetic modeling study of premixed NH₃/CH₄/O₂/Ar flames at low pressure, *Combustion and Flame*, 156 (2009) 1413-1426.
- [17] A. Hayakawa, T. Goto, R. Mimoto, Y. Arakawa, T. Kudo, H. Kobayashi, Laminar burning velocity and Markstein length of ammonia/air premixed flames at various pressures, *Fuel*, 159 (2015) 98-106.
- [18] T. Mendiara, P. Glarborg, Ammonia chemistry in oxy-fuel combustion of methane, *Combustion and Flame*, 156 (2009) 1937-1949.
- [19] A.A. Konnov, Implementation of the NCN pathway of prompt-NO formation in the detailed reaction mechanism, *Combustion and Flame*, 156 (2009) 2093-2105.

- [20] C. Duynslaegher, H. Jeanmart, J. Vandooren, Flame structure studies of premixed ammonia/hydrogen/oxygen/argon flames: Experimental and numerical investigation, *Proceedings of the Combustion Institute*, 32 (2009) 1277-1284.
- [21] Åbo Akademi (ÅA) scheme, Åbo Akademi University, <http://www.abo.fi/fakultet/ookforskkinetschem>, in, 2005.
- [22] M. Zieba, A. Brink, A. Schuster, M. Hupa, G. Scheffknecht, Ammonia chemistry in a flameless jet, *Combustion and Flame*, 156 (2009) 1950-1956.
- [23] V. GRI-Mech, Gas Research Institute, GRI-Mech, Ver. 3.0. < <http://www.me.berkeley.edu/gri-mech/>>. in.
- [24] J.F.G. MARCUS S. DAY, JOHN B. BELL, CHRISTOPHER J. POPE, Ammonia Conversion and NOx Formation in Laminar Coflowing Nonpremixed Methane-Air Flames, *COMBUSTION AND FLAME*, 131 (2002) 285–298.
- [25] M. Goswami, J.G.H. van Griensven, R.J.M. Bastiaans, A.A. Konnov, L.P.H. de Goey, Experimental and modeling study of the effect of elevated pressure on lean high-hydrogen syngas flames, *Proceedings of the Combustion Institute*, 35 (2015) 655-662.
- [26] Ø. Skreiberg, P. Kilpinen, P. Glarborg, Ammonia chemistry below 1400 K under fuel-rich conditions in a flow reactor, *Combustion and Flame*, 136 (2004) 501-518.
- [27] B. Li, Y. He, Z. Li, A.A. Konnov, Measurements of NO concentration in NH₃-doped CH₄+air flames using saturated laser-induced fluorescence and probe sampling, *Combustion and Flame*, 160 (2013) 40-46.
- [28] H.J. C. Duynslaegher, Kinetics in Ammonia-containing Premixed Flames And a Preliminary Investigation of Their Use as Fuel in Spark Ignition Engines, *Combustion science and technology*, 181 (2009) 1092-1106.
- [29] A. Valera-Medina, R. Marsh, J. Runyon, D. Pugh, P. Beasley, T. Hughes, P. Bowen, Ammonia–methane combustion in tangential swirl burners for gas turbine power generation, *Applied Energy*, (2016).
- [30] S.J. Schultz E, Validation of detailed reaction mechanisms for detonation simulation, in: Technical report FM99-5, California Institute of Technology, Pasadena, CA, 2000.
- [31] M. Chaos, F.L. Dryer, Syngas Combustion Kinetics and Applications, *Combustion Science and Technology*, 180 (2008) 1053-1096.
- [32] J. Herzler, C. Naumann, Shock-tube study of the ignition of methane/ethane/hydrogen mixtures with hydrogen contents from 0% to 100% at different pressures, *Proceedings of the Combustion Institute*, 32 (2009) 213-220.
- [33] J. Strohle, T. Myhrvold, An evaluation of detailed reaction mechanisms for hydrogen combustion under gas turbine conditions, *International Journal of Hydrogen Energy*, 32 (2007) 125-135.
- [34] T. Rutar, P.C. Malte, NO_x Formation in High-Pressure Jet-Stirred Reactors With Significance to Lean-Premixed Combustion Turbines, *Journal of Engineering for Gas Turbines and Power*, 124 (2002) 776.
- [35] V. Fichet, M. Kanniche, P. Plion, O. Gicquel, A reactor network model for predicting NO_x emissions in gas turbines, *Fuel*, 89 (2010) 2202-2210.